

# PENTAX™

Digital Camera

# Optio 750Z

## Operating Manual

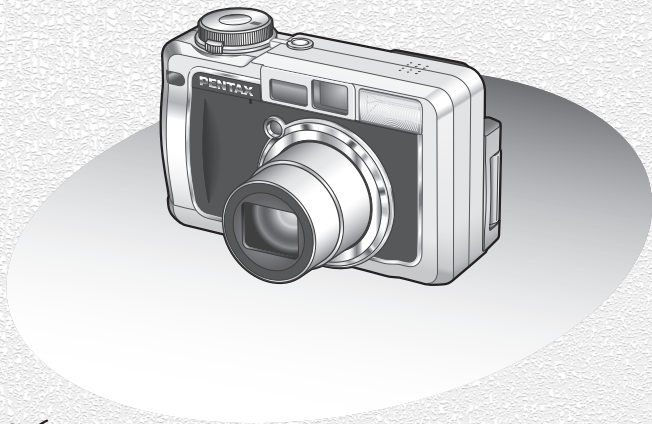

To ensure the best performance from your camera, please read the Operating Manual before using the camera.

Thank you for buying the PENTAX Optio 750Z Digital Camera. Please read this manual before using the camera in order to get the most out of all the features and functions. Keep this manual safe, as it can be a valuable tool in helping you to understand all the camera's capabilities.

### **Regarding copyrights**

Images taken using the Optio 750Z that are for anything other than personal enjoyment cannot be used without permission according to the rights as specified in the Copyright Act. Please take care, as there are even cases where limitations are placed on taking pictures even for personal enjoyment during demonstrations, industrial enterprise or as items for display. Images taken with the purpose of obtaining copyrights also cannot be used outside the scope of use of the copyright as laid out in the Copyright Act, and care should be taken here also.

### **Regarding trademarks**

- PENTAX is a trademark of PENTAX Corporation.
- Optio is a trademark of PENTAX Corporation.
- The SD logo  is a trademark.
- All other brands or product names are trademarks or registered trademarks of their respective companies.

### **To users of this camera**

- There is a possibility that recorded data may be erased or that the camera may not function correctly when used in surroundings such as installations generating strong electromagnetic radiation or magnetic fields.
- The liquid crystal panel used in the LCD display is manufactured using extremely high precision technology. Although the level of functioning pixels is 99.99% or better, you should be aware that 0.01% or fewer of the pixels may not illuminate or may illuminate when they should not. However, this has no effect on the recorded image.
- This product supports PRINT Image Matching. Combination of use, PRINT Image Matching enables digital still cameras, printers and software help photographers to produce images which are more faithful to their intentions. Copyright 2001 Seiko Epson Corporation. All Rights Reserved. PRINT Image Matching is a trademark of Seiko Epson Corporation.

### **Regarding PictBridge**

PictBridge allows the user to connect the printer and digital camera directly, using the unified standard for the direct printout of images. You can print images directly from the camera through a few simple operations.

- There is a possibility that the illustrations and the display screen of the LCD monitor in this manual are different from the actual product.

## FOR SAFE USE OF YOUR CAMERA

Sufficient attention has been paid to the safety of this product but please pay particular attention to the warnings indicated by the following symbols during use.



### **Warning**

These symbols indicate that it is possible that the user may experience serious difficulties if the warnings are not heeded.



### **Caution**

These symbols indicate that it is possible that the user may experience minor or middling difficulties or physical difficulties if the warnings are not heeded.

## About the Camera



### **Warning**

- Do not attempt to take the camera apart or remodel the camera. High voltages are present within the camera, and there is therefore a danger of electric shocks.
- If the inside of the camera should become exposed as a result of, for example, the camera being dropped, please do not under any circumstances touch such exposed portions, as there is a danger of receiving an electric shock.
- To avoid the risk of it being swallowed by mistake, keep the SD Memory Card out of the reach of small children. Seek medical attention immediately if accidentally swallowed.
- Wrapping the strap of the camera around your neck is also dangerous. Please take care that small children do not hang the strap around their necks.
- Use an AC adapter that is of the power and voltage specified for exclusive use with this product. The use of an AC adapter other than that specified exclusively for use with this product may cause fire or electric shocks.
- If the camera emits smoke or a strange smell, or in the event of any other irregularity, stop using the camera immediately, remove the battery and disconnect the AC adapter and contact your nearest PENTAX service center. Continued use of the camera may result in fire or electric shock.

## **Caution**

- Never try to disassemble or short the battery. Also, do not dispose of the battery in fire, as it may explode.
- Do not charge any batteries other than rechargeable lithium-ion battery D-LI7. The battery could explode or catch fire.
- Do not place your finger on the flash when it is discharging as there is a risk of burns.
- Do not discharge the flash while it is touching your clothing as there is a risk of discoloring.
- If any of the battery leakage should come in contact with your eyes, do not rub them. Flush your eyes with clean water and get medical attention immediately.
- If any of the battery leakage should come in contact with skin or clothes, wash the affected areas thoroughly with water.
- Remove the battery from the camera immediately if it becomes hot or begins to smoke. Be careful not to burn yourself during removal.
- Some portions of the camera heat up during use, so please take care, as there is a risk of low temperature burns if such portions are held for long periods of time.
- Should the LCD be damaged, be careful of glass fragments. Also, be careful not to allow the liquid crystal to get on your skin or eyes or in your mouth.

## **About the Battery Charger and the AC Adapter**

## **Warning**

- Do not use the product at a voltage other than the specified voltage. Use with a power source or voltage other than that designed can cause a fire or electrical shock. The specified voltage is 100-240V AC.
- Do not disassemble or modify the product. This can cause a fire or electrical shock.
- If the generation of smoke or strange odor from the product or other abnormality occurs, immediately discontinue using and consult a PENTAX Service Center. Continuing to use the product can cause a fire or electrical shock.
- If water should happen to get inside the product, consult a PENTAX Service Center. Continuing to use the product can cause a fire or electrical shock.

- If lightning should be present during using, unplug the power cord and discontinue using. Continuing to use the product can cause damage to the equipment, fire or electrical shock.
- Wipe off the plug of the power cord if it should become covered with dust. This can cause a fire.

### **Caution**

- Do not place heavy objects on the AC plug cord, allow heavy objects to drop onto it or allow the AC plug cord to become damaged due to excessive bending. If the AC plug cord becomes damaged, consult a PENTAX Service Center.
- Do not short or touch the output terminals of the product while it is still plugged in.
- Remove the battery and unplug the AC plug cord when not using the battery charger.
- Do not plug in the AC plug cord with wet hands. This can cause an electrical shock.
- Do not subject the product to strong impacts or allow it to drop onto a hard surface. This can cause a malfunction.
- Do not use the battery charger to charge batteries other than the ones specified. This can cause overheating or malfunctions.

## Care to be Taken During Handling

- Take the Worldwide Service Network that is included in the package. This will be useful if you experience problems abroad.
- When the camera has not been used for a long time, confirm that it is still working properly, particularly prior to taking important pictures (such as at a wedding or during traveling). Contents of the recording cannot be guaranteed for if recording, playback or transferring your data to a computer, etc. is not possible due to a malfunction of your camera or recording media (SD Memory Card), etc.
- The lens on this camera is not exchangeable. The lens is not removable.
- Do not clean the product with organic solvents such as thinner or alcohol benzene.
- Places of high temperature and humidity should be avoided. Particular care should be taken regarding vehicles, which can become very hot inside.

- Storing the camera where pesticides and chemicals are handled should be avoided. Remove from case and store in a well-ventilated place to prevent the camera from becoming moldy during storage.
- Do not use the camera where it may come in contact with rain, water or any other liquid, because the camera is not weather, water, or liquid resistant. Should the camera get wet from rain, splashing water, or any other liquid, wipe it off immediately with a dry soft cloth.
- Ensure that the camera is not subjected to substantial vibrations, shocks or pressure. Place the camera on a cushion for protection when the camera is subjected to the vibrations of a motorbike, car, or ship, etc.
- The temperature range in which the camera can be used is 0°C to 40°C (32°F to 104°F).
- The liquid crystal display will become black at temperatures of approximately 60°C (140°F) but will return to normal when normal temperatures are returned to.
- The response speed of the liquid crystal display becomes slow at low temperatures. This is due to the properties of the liquid crystal and is not a fault.
- Periodic checks are recommended every 1 to 2 years in order to maintain high performance.
- If the camera is subjected to rapid temperature changes, condensation may form on the inside and outside of the camera. Therefore put the camera in a bag or plastic bag, and take the camera out when the difference in temperature has subsided.
- Avoid contact with garbage, dirt, sand, dust, water, toxic gases, salt, etc. as this may cause damage to the camera. If rain or drops of water get onto the camera, please wipe dry.
- Refer to “Precautions When Using an SD Memory Card” (p.19) regarding the SD Memory Card.
- Please do not press forcefully on the LCD monitor. This could cause breakage or malfunction.
- When using a tripod with the camera, be careful not to overtighten the screw in the tripod socket on the camera.

#### LED Safety Standard

This device is a digital still camera that conforms to the safety standard (IEC60825-1) for a Class 1 LED product.

# Contents

FOR SAFE USE OF YOUR CAMERA .....	1
Care to be Taken During Handling .....	3
Contents .....	5
Composition of the Operating Manual .....	9
Checking the Contents of the Package .....	10
Names of Parts .....	11
Names of Operating Parts .....	12
<b>Getting Started</b> .....	<b>13</b>
<b>Attaching the Strap</b> .....	<b>13</b>
<b>Powering the Camera</b> .....	<b>14</b>
Charging the Battery .....	14
Installing the Battery .....	15
Using the AC Adapter (optional) .....	17
<b>Installing the SD Memory Card</b> .....	<b>18</b>
Recorded Pixels and Quality Level for Still Pictures .....	20
Recorded Pixels and Quality Level for Movies .....	22
<b>Adjusting the LCD Monitor</b> .....	<b>23</b>
<b>Adjusting the Viewfinder</b> .....	<b>24</b>
<b>Turning the Camera On and Off</b> .....	<b>25</b>
Playback Only Mode .....	26
<b>Initial Settings</b> .....	<b>27</b>
Setting the Display Language .....	28
Setting the Date and Time .....	29
<b>Quick Start</b> .....	<b>32</b>
<b>Taking Still Pictures</b> .....	<b>32</b>
<b>Playing Back Still Pictures</b> .....	<b>35</b>
Playing Back Images .....	35
Playing Back the Previous or Next Image .....	36
Rotating the Displayed Image .....	36
<b>Common Operations</b> .....	<b>38</b>
<b>Understanding the Button Functions</b> .....	<b>38</b>
Capture Mode .....	38
Playback Mode .....	40
<b>Using the Menus</b> .....	<b>42</b>
How to Use the Menu .....	42
Example of Menu Operation .....	44
Menu List .....	46
<b>Taking Pictures</b> .....	<b>48</b>
<b>Taking Pictures</b> .....	<b>48</b>
Selecting a Shooting Mode .....	48













Letting the Camera Set the Exposure (Program Mode) .....	49
Aperture Priority Shooting .....	50
Shutter Priority Shooting.....	51
Manual Shooting.....	52
Using Preset Function Settings (User Mode) .....	53
Selecting the Picture Mode According to the Shooting Scene (Picture Mode).....	55
Using the Zoom .....	57
Setting the Exposure (EV Compensation).....	59
Continuous Shooting (Continuous Shooting Mode) .....	60
Using the Self-Timer.....	61
Automatically Changing the Shooting Conditions (Auto Bracket)...	63
Taking Pictures at Fixed Intervals (Interval Shooting) .....	66
Superimposing One Picture on Top of Another (Multiple Exposure Mode).....	69
Using the Remote Control Unit (optional).....	72
Taking Pictures with Digital Filters (Digital Filter Mode) .....	74
Taking Panorama Pictures (Panorama Assist).....	75
Taking 3D Pictures (3D Image Mode) .....	77
<b>Displaying Shooting Information in Capture Mode .....</b>	<b>81</b>
<b>Setting the Shooting Functions.....</b>	<b>84</b>
Selecting the Focus Mode .....	84
Selecting the Flash Mode .....	87
Adjusting the Flash Intensity.....	89
Selecting the Recorded Pixels.....	91
Selecting the Quality Level .....	93
Adjusting the White Balance.....	95
Setting the Autofocus Conditions .....	97
Setting the Light Metering Range to Determine the Exposure (AE Metering) .....	100
Setting the Sensitivity .....	101
Setting the Instant Review Time (Instant Review).....	102
Selecting the Image Tone.....	103
Setting the Image Sharpness (Sharpness).....	104
Setting the Color Saturation (Saturation).....	105
Setting the Image Contrast (Contrast).....	106
<b>Saving the Settings (Memory) .....</b>	<b>107</b>
<b>Taking Movies .....</b>	<b>109</b>
Recording Movies.....	109
Selecting the Recorded Pixels for Movies .....	111
Adding a Color Effect to Movies (Color Mode) .....	112
Selecting the Frame Rate.....	113
Taking Time-lapse Movies.....	114
<b>Playing Back and Deleting Images .....</b>	<b>116</b>
<b>    Playing Back Still Pictures.....</b>	<b>116</b>
Switching between Capture Mode and Playback Mode .....	116
Playing Back Still Pictures .....	116



Nine-Image Display and Folder Display .....	117
Zoom Display.....	119
Displaying Shooting Information in Playback Mode .....	121
Slideshow .....	123
<b>Playing Back Movies .....</b>	<b>125</b>
Playing Back Movies .....	125
<b>Viewing Still Pictures and Movies on a TV .....</b>	<b>126</b>
<b>Deleting.....</b>	<b>127</b>
Deleting Single Images and Sound Files.....	127
Deleting Selected Images and Sound Files (from Nine-Image Display).....	129
Deleting All Images.....	130
Protecting Images and Sound Files from Deletion (Protect) .....	131
<b>Editing and Printing Still Pictures .....</b>	<b>133</b>
<hr/>	
<b>Editing Still Pictures .....</b>	<b>133</b>
Changing the Image Size and Quality (Resize).....	133
Trimming Images .....	135
Editing Pictures with Digital Filters .....	137
<b>Setting the Printing Service (DPOF).....</b>	<b>139</b>
Printing Single Images.....	139
Printing All Images.....	141
<b>Direct Printing Using PictBridge .....</b>	<b>142</b>
Connecting the Camera to the Printer .....	142
Printing Single Images.....	143
Printing All Images.....	144
Printing Images Using the DPOF Settings .....	145
Disconnecting the Camera from the Printer .....	145
<b>Recording and Playing Back Sound .....</b>	<b>146</b>
<hr/>	
<b>Recording Sound (Voice Recording Mode).....</b>	<b>146</b>
<b>Playing Back Sound .....</b>	<b>147</b>
<b>Adding a Voice Memo to Images.....</b>	<b>148</b>
Recording a Voice Memo .....	148
Playing Back a Voice Memo.....	149
<b>Settings .....</b>	<b>150</b>
<hr/>	
<b>Camera Settings.....</b>	<b>150</b>
Formatting an SD Memory Card.....	150
Changing the Date and Time.....	151
Changing the Sound Settings.....	152
Setting the World Time .....	154
Changing the Display Language .....	155
Changing the Image Folder Name .....	156
Changing the Start-up Screen .....	157
Customizing the Display Mode .....	158
Adjusting the Brightness of the LCD Monitor.....	159
Changing the Video Output Format.....	160

Changing the USB Connection Mode.....	161
Setting Sleep Timeout .....	162
Setting Auto Power Off .....	163
Resetting to Default Settings (Reset) .....	163
Registering Functions on the Fn Button .....	164
<b>Setting the Alarm .....</b>	<b>166</b>
Checking the Alarm .....	166
Setting the Alarm .....	167
Stopping the Alarm .....	168
<b>Digital Exposure Metering Function .....</b>	<b>169</b>
<hr/>	
<b>Digital Exposure Metering Function .....</b>	<b>169</b>
Digital Exposure Metering Mode .....	169
Setting Up the Digital Exposure Metering Mode.....	169
Metering the Exposure .....	171
Using the Reflected Light Exposure Meter .....	174
<b>Appendix .....</b>	<b>177</b>
<hr/>	
<b>List of World Time Cities.....</b>	<b>177</b>
<b>Rec. Mode Menus for Each Operation Mode.....</b>	<b>178</b>
<b>Default Settings.....</b>	<b>179</b>
<b>Optional Accessories .....</b>	<b>184</b>
<b>Messages.....</b>	<b>185</b>
<b>Troubleshooting.....</b>	<b>187</b>
<b>Main Specifications .....</b>	<b>190</b>
<b>WARRANTY POLICY.....</b>	<b>194</b>

The meanings of the symbols used in this operating manual are explained below.

	indicates the reference page number for an explanation of the related operation.
	indicates information that is useful to know.
	indicates precautions to be taken when operating the camera.
<b>USER, M, Tv, Av,</b>        	The icons above the title show the Capture modes that can activate the function. Ex. 
<b>Setting the Image Sharpness (Sharpness)</b>	

# Composition of the Operating Manual

This operating manual contains the following chapters.

- 1 Getting Started** \_\_\_\_\_  
This chapter explains what you need to do after purchasing the camera before you start taking pictures. Be sure to read it and follow the instructions.
- 2 Quick Start** \_\_\_\_\_  
This chapter explains the simplest way to take pictures and play back images. Use it if you want to start taking pictures or playing back images straightaway.
- 3 Common Operations** \_\_\_\_\_  
This chapter explains common operations such as the functions of the buttons and how to use the menus. For more details, refer to the respective chapters below.
- 4 Taking Pictures** \_\_\_\_\_  
This chapter explains the various ways of taking still pictures and how to set the relevant functions.
- 5 Playing Back and Deleting Images** \_\_\_\_\_  
This chapter explains how to view still pictures and movies on the camera or on a TV and how to delete images from the camera.
- 6 Editing and Printing Still Pictures** \_\_\_\_\_  
This chapter explains the various ways of printing still pictures and how to edit images with the camera. For instructions on how to print or edit images using a computer, refer to the "PC Guide – Enjoying Your Digital Camera Images On Your PC".
- 7 Recording and Playing Back Sound** \_\_\_\_\_  
This chapter explains how to record sound only or add sound (a voice memo) to an image, and how to play back voice memos.
- 8 Settings** \_\_\_\_\_  
This chapter explains how to set the camera-related functions.
- 9 Digital Exposure Metering Function** \_\_\_\_\_  
This chapter explains how to use the camera as a digital exposure metering.
- 10 Appendix** \_\_\_\_\_  
This chapter explains troubleshooting, and introduces optional accessories.

1

2

3

4

5

6

7

8

9

10

## Checking the Contents of the Package



Camera  
Optio 750Z

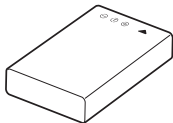

Rechargeable lithium-ion  
battery D-LI7 (\*)

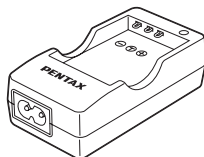

Battery charger  
D-BC7 (\*)

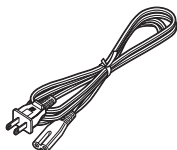

AC plug cord  
D-CO2 (\*)

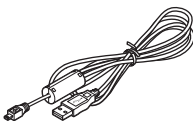

USB cable  
I-USB7 (\*)

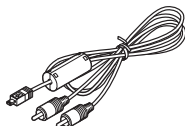

AV cable  
I-AVC7 (\*)

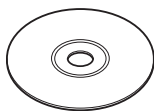

Software (CD-ROM)  
S-SW22

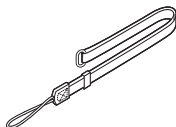

Strap  
O-ST17 (\*)



SD Memory Card  
(32 MB)



Operating Manual  
(this manual)

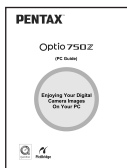

Operating Manual  
(PC Guide)

Items marked with an asterisk (\*) are also available as optional accessories. For other optional accessories, refer to "Optional Accessories" (p.184).

# Names of Parts

## Front

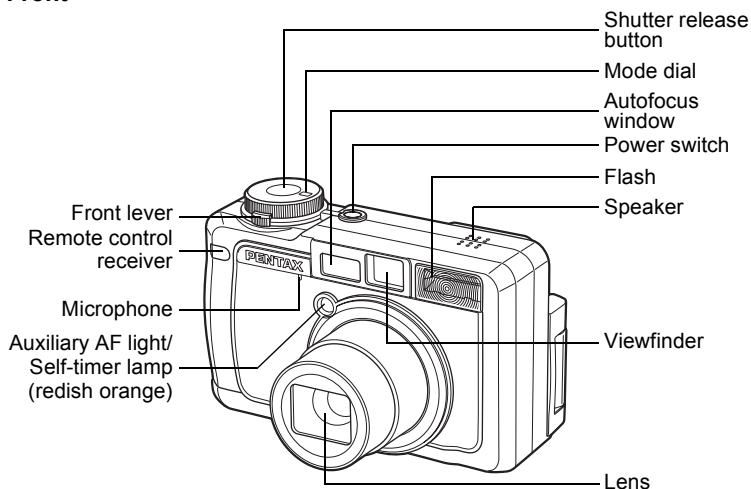

## Back

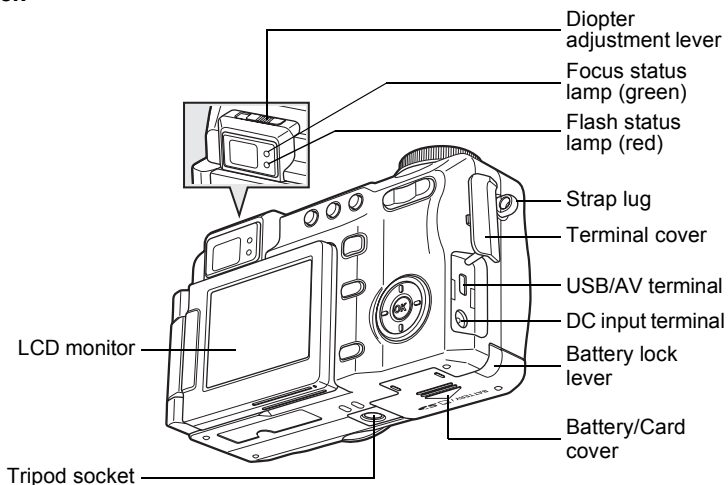

## Names of Operating Parts

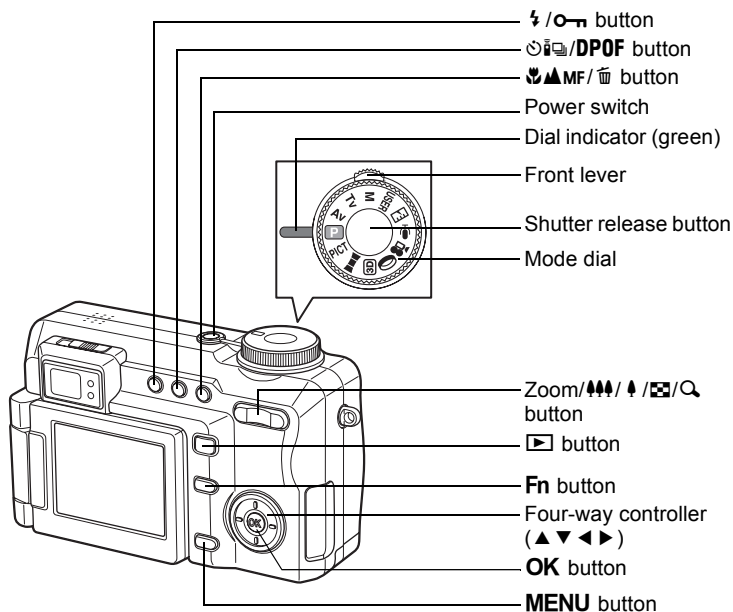

### Guide Indications

A guide to available button operations appears on the LCD monitor during operation.

The buttons are indicated as shown below.

Four-way controller (▲)	▲
Four-way controller (▼)	▼
Four-way controller (◀)	◀
Four-way controller (▶)	▶
<b>MENU</b> button	
Shutter release button	
<b>Fn</b> button	

Zoom /  /  button	
When trimming an image	
<b>DPOF</b> button	
button	
button	
<b>OK</b> button	
Front lever	

# Attaching the Strap

The provided strap (O-ST17) can be attached, as is, to the camera to create a neck strap from which to carry the camera. The strap can also be shortened and then attached to the camera to create a compact hand strap.

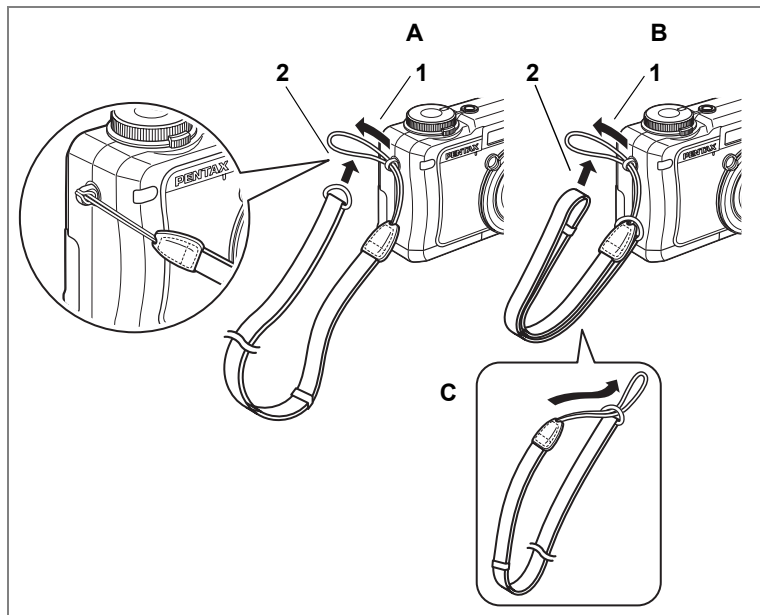

- 1** Pass the narrow end of the strap through the strap lug.
- 2** Pass the strap end through the loop and tighten.

## Shortening the Strap

You can create a short hand strap for the camera by passing the narrow end of the strap through the metal ring on the end of the strap (C). The shortened strap can then be attached to the camera (B).

# Powering the Camera

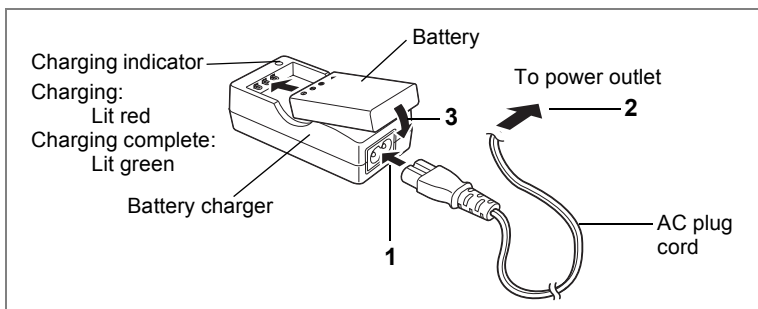

## Charging the Battery

Charge the battery when using the camera for the first time, when the camera has not been used for a long time, or when the [Battery depleted] message is displayed.

- 1 Connect the AC plug cord to the battery charger D-BC7.**
- 2 Plug the AC plug cord into the power outlet.**
- 3 Place the battery in the charger with the label facing up.**  
The charging indicator lights red when charging.  
The charging indicator lights green when charging is completed.
- 4 When charging is completed, remove the battery from the battery charger.**



- The time required for full charge is about 180 minutes maximum. The appropriate ambient temperature range for charging the battery is 0°C - 40°C (32°F to 104°F). The charging time may vary depending on the ambient temperature and charging conditions.
- The battery has reached the end of its service life when the time the camera can be operated becomes shorter even when the battery is fully charged. Replace with a new battery.



- Use the battery charger D-BC7 to charge the rechargeable lithium-ion battery D-LI7 only, as the charger may overheat or be damaged.
- If the battery is inserted correctly but the charging indicator fails to light, the battery may be faulty. Replace with a new battery.



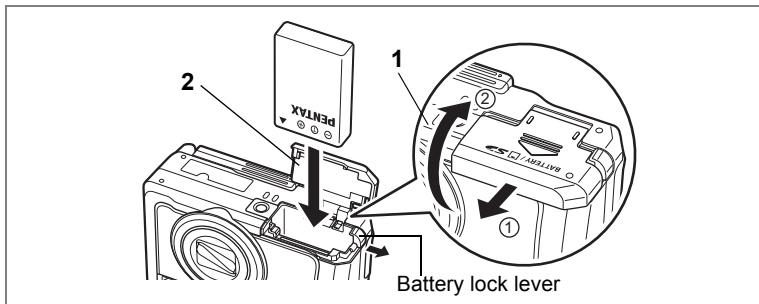

## Installing the Battery

Install the battery provided with the camera. Charge the battery before installing it when using the camera for the first time.

- 1 Open the battery/card cover.**  
Slide the battery/card cover in the direction indicated by the arrow ① and flip the cover open ②.
- 2 Insert the battery with the ▲ symbol facing toward the camera lens, and push the battery in while pressing the battery lock lever on the battery side in the direction of the arrow.**  
Push the battery in until it locks.
- 3 Close the battery/card cover.**

## Removing the Battery

- 1 Open the battery/card cover.**
- 2 Press the battery lock lever in the same direction as when you inserted the battery.**  
Pull the battery out.



If you intend to use the camera continuously for a long period, use of the AC adapter D-AC7 (optional) is recommended. (p.17)



- The rechargeable lithium-ion battery D-LI7 is only for use with this camera. Use of other batteries may damage the camera and render it unusable.
- Insert the battery correctly. If the battery is incorrectly oriented, malfunction may result.
- Do not remove the battery when the camera is turned on.
- If you do not intend to use the camera for a long time, remove the battery.
- If the camera is left without the battery for a long time, the date will be reset.

### • Image Storage Capacity, Recording Time and Playback Time (at 23°C, LCD monitor on with fully charged battery D-LI7)

Image Storage Capacity (using the flash for 50% of shots)	Playback Time
Approx. 245 pictures	Approx. 4 hr. 30 min.





- The still picture storage capacity is based on measuring conditions in accordance with CIPA standards and the playback time is based on PENTAX measuring conditions. Some deviation from the above figures may occur in actual use depending on shooting conditions.



- In general, battery performance may temporarily deteriorate as the temperature decreases.
- Be sure to take a spare battery with you when traveling or using the camera in a cold region, or if you intend to take a lot of pictures.

### • Battery Level Indicator

You can check the battery level by the  symbol on the LCD monitor.

Screen Display	Battery Status
 (Green)	Adequate power remains.
 (Green)	Battery is running low.
 (Yellow)	Battery is running very low.
 (Red)	Battery is exhausted.
[Battery depleted]	The camera will turn off after this message appears.

### • Recycling Batteries



Li-ion

This symbol indicates that the battery is recyclable. Cover the terminals with insulating tape and take the battery to a store displaying this symbol.

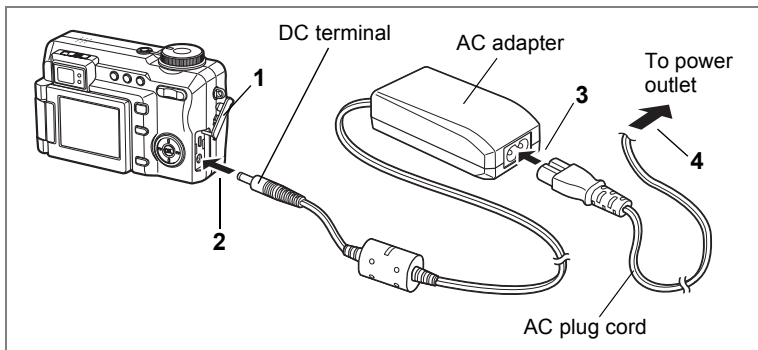

## Using the AC Adapter (optional)

If you intend to use the camera for a long time or connect the camera to a computer, use of the AC adapter D-AC7 is recommended.

- 1 Make sure that the camera is turned off and open the terminal cover.**
- 2 Connect the DC terminal of the AC adapter to the DC input terminal on the camera.**
- 3 Connect the AC plug cord to the AC adapter.**
- 4 Plug the AC plug cord into the power outlet.**



- Make sure that the camera is turned off when connecting and disconnecting the AC adapter.
- Make sure that the AC plug cord and connecting cable are inserted securely. The data may be lost if the cable becomes disconnected while you are taking pictures.
- To avoid the risk of fire or electric shock when using the battery charger or AC adapter, be sure to read the section on "FOR SAFE USE OF YOUR CAMERA" (p.1).
- Be sure to read the operation manual accompanying the AC adapter before using the adapter.
- The battery cannot be charged inside the camera even when the AC adapter is connected.

# Installing the SD Memory Card

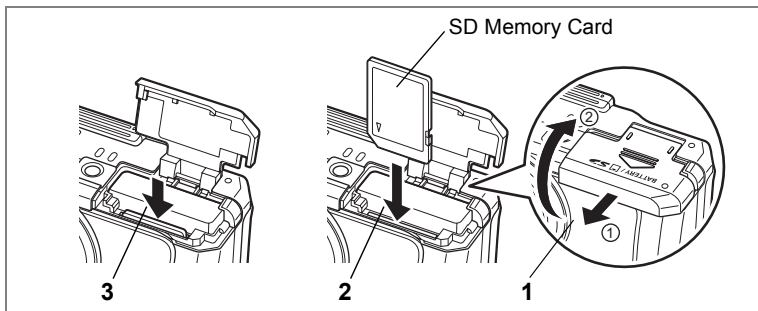

This camera uses an SD Memory Card to record captured images and recorded sound.

Make sure that the camera is turned off before inserting or removing the SD Memory Card.

## 1 Open the battery/card cover.

Slide the battery/card cover in the direction indicated by the arrow ① and flip the cover open ②.

## 2 Insert an SD Memory Card so the label is facing toward the lens and push the card in until it clicks.

Images and sound may not be recorded correctly if the card is not inserted all the way.

## 3 Close the battery/card cover.

To remove the card, press the card in to eject it and pull it out.



- The image storage capacity varies depending on the capacity of the SD Memory Card and the selected number of recorded pixels and quality level. (p.21)
- The focus status lamp and flash status lamp blink while the SD Memory Card is being accessed (data is being recorded or read).

## Precautions When Using an SD Memory Card

- The SD Memory Card is equipped with a write-protect switch. Setting the switch to LOCK protects the existing data by prohibiting recording of new data, deletion of existing data or formatting of the card.

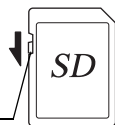

Write-protect switch

- ☒ appears on the LCD monitor when the card is write-protected.
- Care should be taken when removing the SD Memory Card immediately after using the camera, as the card may be hot.
- Do not remove the SD Memory Card or turn the camera off while data is being recorded on the card, images or sound files are being played back, or the camera is connected to a computer with the USB cable, as this may cause the data to be lost or the card to be damaged.
- Do not bend the SD Memory Card or subject it to violent impact. Keep it away from water and store away from high temperature.
- Be sure to format unused cards or cards that have been used on another camera. Refer to "Formatting an SD Memory Card" (p.150) for instructions on formatting.
- Do not remove the SD Memory Card during formatting as this may damage the card and render it unusable.
- The data on the SD Memory Card may be deleted in the following circumstances. PENTAX does not accept any liability for data that is deleted
  - (1) when the SD Memory Card is mishandled by the user.
  - (2) when the SD Memory Card is exposed to static electricity or electrical interference.
  - (3) when the card has not been used for a long time.
  - (4) when the card is ejected, the AC adapter is disconnected or the battery is removed while the data on the card is being recorded or read.
- The SD Memory Card has a limited service life. If it is not used for a long time, the data on the card may become unreadable. Be sure to make a backup of important data on a computer.
- Avoid using or storing the card where it may be exposed to static electricity or electrical interference.
- Avoid using or storing the card in direct sunlight or where it may be exposed to rapid changes in temperature or to condensation.
- When using an SD Memory Card with a slow recording speed, recording may stop while you are taking movies even when there is adequate space in the memory, or shooting and playback may take a long time.
- For information on compatible memory cards, visit the PENTAX website or contact your nearest PENTAX customer service center.

## Recorded Pixels and Quality Level for Still Pictures

1

Getting Started

Choose the number of recorded pixels and quality level best suited to your purpose.

Higher quality levels and numbers of recorded pixels produce clearer images for printing, but the resulting increase in data volume reduces the total number of pictures that can be taken.

The quality of the printed picture depends on the image quality, exposure control, resolution of the printer and other factors; therefore, you do not need select more than the required number of recorded pixels.

1024×768 is sufficient for printing a postcard-size print.

4:3 is a normal aspect ratio of the images captured with a digital camera. When printing an image with no border and an aspect ratio of 4:3, part of the image may not appear on the print. Set the aspect ratio to 3:2 for prints with more of the original image.

### ● Appropriate Number of Recorded Pixels According to Use

Aspect Ratio of Image		Use
4:3	3:2	
3056×2296	3056×2040	↑ Suitable for high-quality prints, large-sized prints and image processing  Suitable for postcard-size prints Suitable for use on websites or attaching to e-mails
2592×1944	2592×1728	
2048×1536	2048×1368	
1600×1200	1600×1064	
1024×768	1024×680	
640×480	640×424	

The default setting is **3056×2296** with a **4:3** aspect ratio.

### ● Appropriate Quality Level According to Use

TIFF		Captures the image as uncompressed TIFF data. Suitable for editing images with the ACDSee software provided with the camera. This can only be specified with the recorded pixels 3056×2296 and 2592×1944.
★★★	Best	Lowest compression rate. Suitable for photo prints.
★★	Better	Standard compression rate. Suitable for viewing the image on a computer screen.
★	Good	Highest compression rate. Suitable for attaching to e-mails or creating websites.

The default setting is **★★**.

Choose the appropriate number of recorded pixels and quality level for still pictures on the [📷 Rec. Mode] menu.

Selecting the Recorded Pixels 📷 p.91

Selecting the Quality Level 📷 p.93

1

● Recorded Pixels, Quality Level and Approximate Recordable Images

Recorded pixels (4:3) \ Quality level	TIFF	★★★ Best	★★ Better	★ Good
3056×2296	2 pictures	15 pictures	30 pictures	47 pictures
2592×1944	4 pictures	22 pictures	44 pictures	67 pictures
2048×1536	—	34 pictures	67 pictures	101 pictures
1600×1200	—	56 pictures	110 pictures	149 pictures
1024×768	—	121 pictures	215 pictures	298 pictures
640×480	—	258 pictures	352 pictures	484 pictures

Recorded pixels (3:2) \ Quality level	TIFF	★★★ Best	★★ Better	★ Good
3056×2040	—	17 pictures	34 pictures	56 pictures
2592×1728	—	24 pictures	47 pictures	75 pictures
2048×1368	—	38 pictures	75 pictures	121 pictures
1600×1064	—	61 pictures	121 pictures	184 pictures
1024×680	—	149 pictures	242 pictures	322 pictures
640×424	—	298 pictures	387 pictures	484 pictures

- The above table shows the approximate number of images when using a 64MB SD Memory Card.
- The above figures are based on measuring conditions in accordance with CIPA standards. They may vary depending on the subject, shooting conditions, shooting mode, SD Memory Card, etc.

## Recorded Pixels and Quality Level for Movies

Choose the number of recorded pixels and quality level best suited to your purpose.

The number of recorded pixels indicates the image resolution. Larger numbers produce clearer movie images, but result in larger filesizes. The frame rate indicates the number of images that are displayed per second. Higher numbers produce smoother motion, but also result in larger filesizes.

Choose the appropriate number of recorded pixels and quality level for movies on the [  Rec. Mode ] menu.

Selecting the Recorded Pixels for Movies  p.111

Selecting the Frame Rate  p.113

### ● Appropriate Number of Recorded Pixels According to Use

640×480	Produces high quality movies at VGA size, but with a shorter recording time.
320×240	Produces smaller images, but with a longer recording time.

The default setting is 640×480.

### ● Appropriate Frame Rate According to Use (frames/sec.)

30fps	Produces movies with smoother movement, but with a shorter recording time.
15fps	Records using less number of frames, but with a longer recording time.

The default setting is 15 frames/sec. (fps).

### ● Recorded Pixels, Frame Rate and Approximate Recording Time

Recorded Pixels \ Frame Rate	30fps	15fps	Sound
	640×480	50 sec.	
320×240	1 min. 30 sec.	2 min. 50 sec.	2 hr. 12 min

- The above table shows the approximate recording time when using a 64MB SD Memory Card.
- The above table is based on standard shooting conditions specified by PENTAX and may vary depending on the subject, shooting conditions, SD Memory Card, etc.



# Adjusting the LCD Monitor

The LCD monitor can be swiveled 180 degrees horizontally and 270 degrees vertically.

This is convenient for recording yourself with Self-portrait mode, recording at a low angle, or recording with the camera above your head.



Do not apply excessive force when swiveling the LCD monitor.

## Opening the LCD monitor

Open the LCD monitor from the right end.

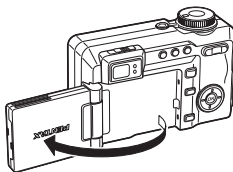

## Swiveling the LCD monitor

The LCD monitor can be swiveled 270 degrees downward, toward you.

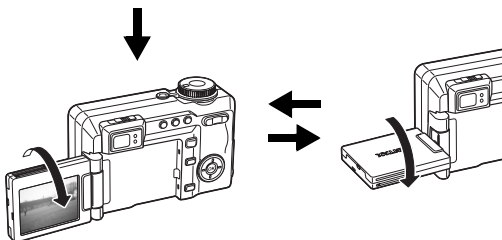

## Closing the LCD monitor

To protect the LCD monitor, close the LCD monitor when the camera is not in use.

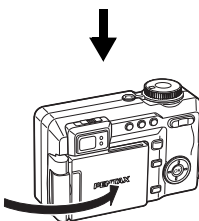

When you aim the LCD monitor at yourself to take a picture of yourself, the image you see in the LCD monitor will be a mirror image, but the resulting picture will be the view seen through the lens.

# Adjusting the Viewfinder

1

Getting Started

Diopter adjustment  
lever

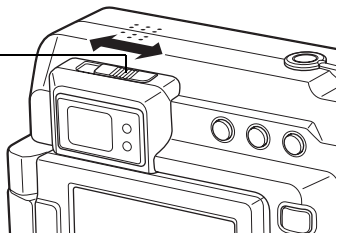

The viewfinder can be adjusted to suit your eyesight. Slide the diopter adjustment lever to the right or left to make the viewfinder display sharper.

The diopter can be adjusted in the range of  $-3 \text{ m}^{-1}$  to  $+1 \text{ m}^{-1}$  ( $-9.8 \text{ ft.}^{-1}$  to  $+3.3 \text{ ft.}^{-1}$ ) diopters.

- 1 Point the camera toward a bright subject, look through the viewfinder and slide the diopter adjustment lever to the right or left.**

The viewfinder can be more easily adjusted when pointing the camera toward printed characters, such as on a calendar, or a similar subject with sharp outlines.

# Turning the Camera On and Off

1

Getting Started

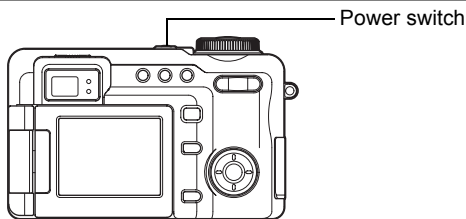

## 1 Press the power switch.

The camera turns on.

The lens cover opens and the lens extends.

If the Initial Settings screen or Date Adjust screen appears when you turn the camera on, follow the procedure on page p.27 to set the display language and/or current date and time.

## 2 Press the power switch again.

The camera turns off and the power switch light turns off.

Taking Pictures p.48

## Checking the Memory Card

The memory card is checked automatically when the camera turns on. appears on the LCD monitor if the camera does not have an SD Memory Card inserted.

appears instead of if the write-protect switch of the SD Memory Card is locked. Images and sound cannot be recorded when the write-protect switch is locked.



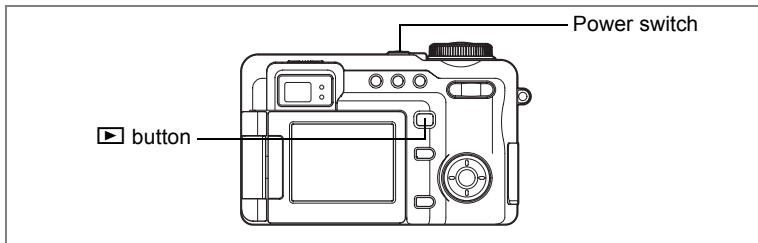

## Playback Only Mode

Use this mode when you want to play back pictures one after another. Pressing the shutter release button does not change the mode to Capture mode.

### 1 Press the power switch while pressing the ▶ button.

The camera turns on in Playback Only mode. The lens does not extend.



- To switch from Playback Only mode to Capture mode, turn the camera off, then turn it on again.
- The camera switches to Playback mode and the lens is retracted when you press and hold down the ▶ button for more than two seconds. To switch from Playback mode to Capture mode, press the ▶ button again, press the shutter release button or turn the mode dial.

Playing Back Still Pictures  p.116

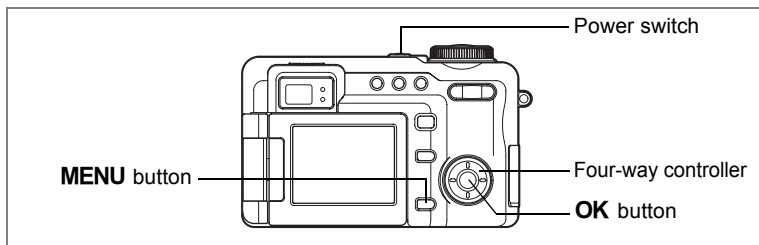

If the Initial Settings screen or Date Adjust screen appears when you turn the camera on, follow the procedure below to set the display language and/or current date and time.

## If the Initial Settings screen appears

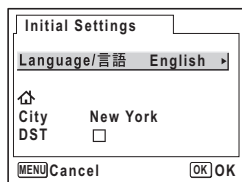

☞ p.28 “Setting the Display Language”

☞ p.29 “Setting the Date and Time”

## If the Date Adjust screen appears

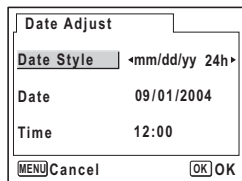

☞ p.29 “Setting the Date and Time”

If neither screen appears, setting is not required.

## Setting the Display Language

You can choose the language in which the menus, error messages, etc. are displayed from the following: English, French, German, Spanish, Italian, Russian, Korean, Chinese and Japanese.

### 1 Press the four-way controller (▶).

The Language/言語 screen appears.

### 2 Use the four-way controller (▲▼◀▶) to choose a language.

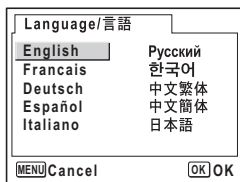

### 3 Press the OK button.

The default setting is English.

### 4 Press the four-way controller (▼).

The screen for setting the city appears.

### 5 Use the four-way controller (◀▶) to choose the desired city (Hometown).

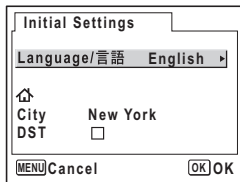

### 6 Press the four-way controller (▼).

The screen for setting DST (Daylight Saving Time) appears.

### 7 Use the four-way controller (◀▶) to select (On) or (Off).

### 8 Press the OK button.

The Date Adjust screen appears.

## Setting the Date and Time

Set the current date and time and the display style.

**1 Press the four-way controller (▶).**

The frame moves to [mm/dd/yy].

**2 Use the four-way controller (▲▼) to choose the date and time display style.**

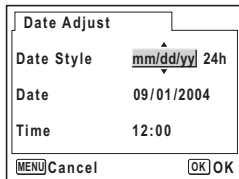

**3 Press the four-way controller (▶).**

The frame moves to [24h].

**4 Use the four-way controller (▲▼) to select [24h] (24-hour display) or [12h] (12-hour display).**

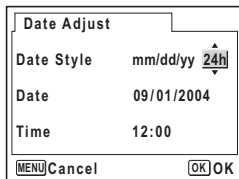

**5 Press the four-way controller (▶).**

The frame returns to [Date Style].

**6 Press the four-way controller (▼).**

The frame moves to [Date].

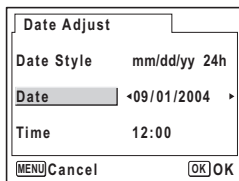

**7 Press the four-way controller (▶).**

The frame moves to month.

**8 Use the four-way controller (▲▼) to change the month.**

Change the day and year in the same manner.

Next, change the time.

If you select [12h] in Step 4, the setting switches between am and pm corresponding to the time.

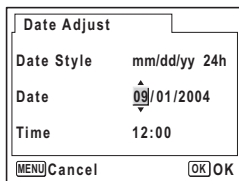

## 9 Press the **OK** button.

The camera is ready to take pictures. If you set the date and time with the menu operations, you will return to the [Y/| Set-up] screen. Press the **OK** button again.



- When you finish the settings and press the **OK** button, the camera clock is reset to 00 seconds.
- To set the exact time, press the **OK** button when the time signal (on the TV, radio, etc.) reaches 00 seconds.



- When the Initial Settings or Date Adjust screen is displayed, you can cancel the setting operation and switch to Capture mode by pressing the **MENU** button. In this case, the Initial Settings screen will appear next time you turn the camera on.
- You can change the language and date and time settings with the menu operations. (p.151, p.155)



## Memo

## Taking Still Pictures

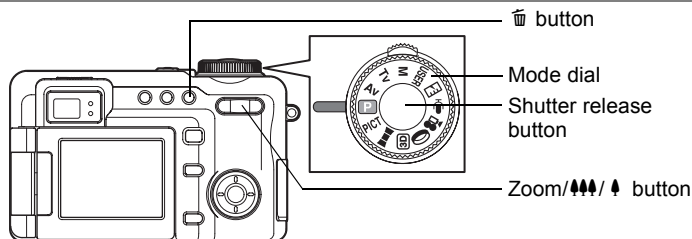

The standard procedure for taking still pictures is described below. The flash fires automatically depending on the light conditions.

- 1 Press the power switch.**  
The camera turns on.
- 2 Set the mode dial to **[P]**.**
- 3 Check the image on the LCD monitor.**

The focus frame in the middle of the LCD monitor indicates the zone of automatic focusing.

You can change the captured area by pressing the Zoom/▲▲▲/▲ button to the right or left.

▲ : enlarges the subject

▲▲▲ : enlarges the area captured by the camera

You can check the captured area by looking through the viewfinder.



Focus frame

**Caution**

The image in the viewfinder always appears with a 4:3 aspect ratio regardless of the aspect ratio setting of the image. Use the LCD monitor when taking pictures with the aspect ratio set to 3:2.

- 4 Press the shutter release button halfway.**  
The focus frame turns green if the subject is in focus.

## 5 Press the shutter release button fully.

The picture is taken.

The image appears on the LCD monitor for two seconds (Instant Review) and is recorded on the SD Memory Card. (p.34)

The green and red lamps on the right of the viewfinder blink alternately while the image is being saved to the SD Memory Card.



The focus frame does not appear in the viewfinder. Always check the focusing area on the LCD monitor.

### Using the Shutter Release Button

The shutter release button works in a two-step action as follows.

#### Press halfway

The focus, exposure and white balance are locked when the shutter release button is pressed lightly (halfway). The shutter speed and aperture settings only appear on the LCD monitor when the shutter release button is pressed halfway. The following information is indicated on the LCD monitor and by the focus status and flash status lamps when the shutter release button is pressed halfway.

#### 1. Focus frame

The green focus frame appears when the subject is in focus. The frame does not appear if the subject is out of focus.

#### 2. Status lamps

	Focus status lamp (green)	Flash status lamp (red)
Lit	Subject is in focus	Flash is ready
Blinks	Subject is not in focus	Flash is charging

#### Press fully

Press the shutter release button all the way down (fully) to take a picture.

[Poor focusing conditions]

The camera may not be able to focus under the following conditions. In this case, lock the focus on an object the same distance away as the subject (by pressing the shutter release button halfway), then aim the camera at your subject and press the shutter release button fully.

- Objects that lack contrast such as a blue sky or white wall
- Dark places or objects, or conditions that prevent light being reflected back
- Horizontal lines or intricate patterns
- Fast moving objects
- When there is an object in the foreground and an object in the background in the same picture
- Strongly reflected light or strong backlighting (bright background)



#### Auxiliary AF Light

When using the Autofocus mode in a dark environment, the Auxiliary AF Light may illuminate the subject.

The Auxiliary AF Light on this camera conforms to the safety standard (IEC60825-1) for a Class 1 LED product. Although looking directly at the Auxiliary AF Light poses no safety concerns, because the light is extremely bright, recommend you not to stare directly at the light at close range.

### Instant Review

The image appears on the LCD monitor for two seconds (Instant Review) immediately after it is captured. You can change the Instant Review time. (p.102)

You can delete the image from Instant Review by pressing the  button.

## Playing Back Still Pictures

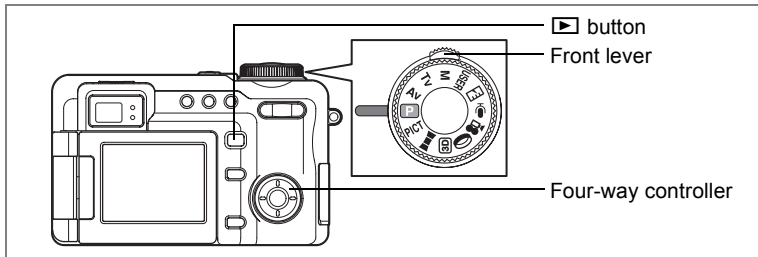

### Playing Back Images

You can play back the images you have taken.

- 1 **Press the ▶ button after taking a picture.**

The image appears on the LCD monitor. This is called Playback mode. To take another picture, press the ▶ button again, press the shutter release button, or turn the mode dial.



### Playing Back Images with the Lens Retracted

To continue playing back, use of the camera with the lens retracted is recommended.

- 1 **Press and hold down the ▶ button for more than two seconds after taking a picture.**

The camera switches to Playback mode and the lens is retracted. To take another picture, press the ▶ button again, press the shutter release button or turn the mode dial.



- If there are no images stored, the [No image and sound] message appears.
- You can enlarge the image by pressing the Zoom//Q button. (p.119)
- For instructions on how to view images on a computer, refer to the “PC Guide – Enjoying Your Digital Camera Images On Your PC”.

## Playing Back the Previous or Next Image

Still pictures can be played back one at a time, proceeding either forward or backward.

- 1 Press the button after taking a picture.**  
The image appears on the LCD monitor.
- 2 Press the front lever to the right or left, or press the four-way controller (◀▶).**  
The previous or next image appears.



## Rotating the Displayed Image

- 1 Press the button after taking a picture.**  
The image appears on the LCD monitor.
- 2 Press the four-way controller (▼).**  
The image is rotated 90 degrees clockwise each time the button is pressed.
- 3 Press the OK button or MENU button.**  
The original image appears.



- Rotated images are played back unrotated in nine-image display.
- Movies cannot be rotated.

## Deleting the Displayed Image

You can delete the image displayed on the LCD monitor by pressing the  button, using the four-way controller () to select [Delete] and pressing the **OK** button. (p.127)

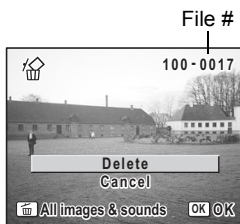

## Understanding the Button Functions

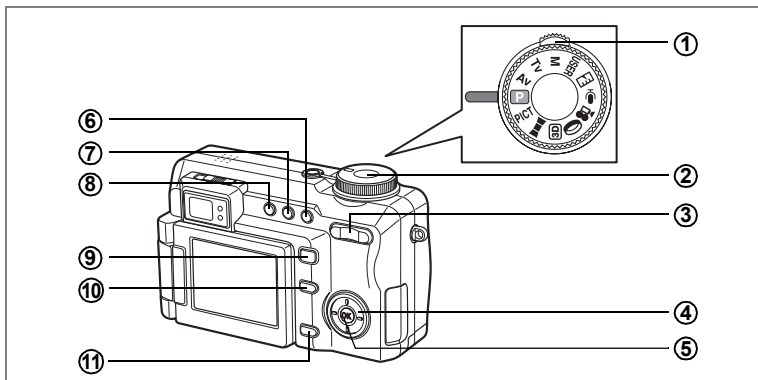

## Capture Mode

- ① **Front lever**  
Adjusts the exposure. Cannot be used in Manual Exposure mode. (☞ p.52)  
Select **USER** mode on the Fn guide screen in **USER** mode.
- ② **Shutter release button**  
Press down halfway to focus on the subject (when Focus mode is not set to **▲** or **MF**). (☞ p.33)  
Press down fully to take a still picture. (☞ p.33)  
Starts and stops movie recording in **MOVIE** mode. (☞ p.109)  
Starts and stops voice recording in **VOICE** mode. (☞ p.146)
- ③ **Zoom/▲▲▲/▲ button**  
Changes the shooting area. (☞ p.57)  
Adjust the focus manually when the Focus mode is set to **MF**.
- ④ **Four-way controller**  
(▲▼) Adjusts the aperture in **Av** mode and **M** mode. (☞ p.50, p.52)  
(◀▶) Adjusts the shutter speed in **Tv** mode and **M** mode. (☞ p.51, p.52)  
(▲▼◀▶) Selects the Picture mode in **PICT** mode. (☞ p.55)



(▲▼◀▶) Recalls the allocated function on the Fn guide screen.  
(☞p.164)

### ⑤ **OK button**

Changes the information displayed on the LCD monitor. (☞p.81)

### ⑥ **🌸▲MF button**

Selects the Focus mode. (☞p.84)

No icon (Autofocus) → 🌸 (Macro) → 🌸 (Super Macro) →

▲ (Infinity) → MF (Manual Focus) → 📄 (Focusing Area)

### ⑦ **🕒📄 button**

Selects the Drive mode. (☞pp.60 - 73)

No icon (Single-Frame Shooting) → 📄 (Continuous Shooting) →

🕒 (Self-Timer) → 📄 (Auto Bracket) → 📄 (Interval Shooting) →

🕒 (Multiple Exposure) → 📄 (Remote Control)

### ⑧ **⚡ button**

Changes the flash mode. (☞p.87)

No icon (Auto Flash) → 🕒 (Flash Off) → ⚡ (Flash On) →

🕒 (Auto + Red-eye Reduction) → 🕒 (Flash On + Red-eye Reduction)

### ⑨ **▶ button**

Switches to the Playback mode. (☞p.35)

### ⑩ **Fn button**

Displays the Fn guide screen. Use this button and the four-way controller (▲▼◀▶) to operate this screen. Set up the functions for the four-way controller in advance. (☞p.164)

### ⑪ **MENU button**

Displays the [📷 Rec. Mode] menu. (☞p.42)

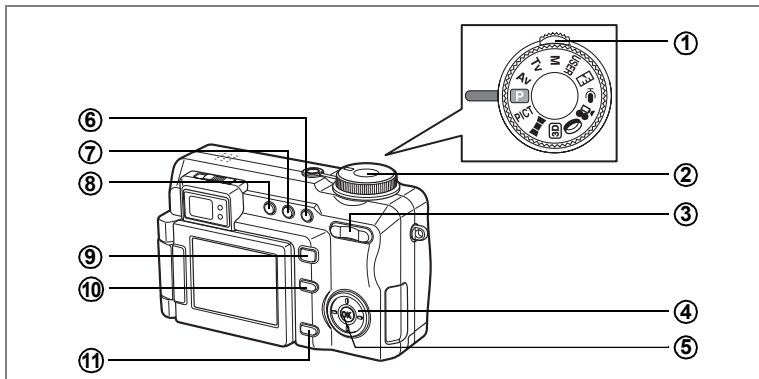

## Playback Mode

### ① Front lever

Displays the next or previous image in single-image display.  
 Displays the next or previous set of nine images in nine-image display.  
 Displays the next or previous set of nine folders in folder display.

### ② Shutter release button

Press down halfway or fully to switch to Capture mode. (☞p.32)

### ③ Zoom/ $\square$ / $\mathcal{Q}$ button

Press  $\square$  in single-image display to switch to nine-image display, and press  $\square$  again to switch to folder display. Press  $\mathcal{Q}$  to return to the previous display. (☞p.117)

Press  $\mathcal{Q}$  to enlarge the image in single-image display. Press  $\square$  to return to the original size. (☞p.119)

### ④ Four-way controller

(▲) Plays back and pauses a movie or voice recording.  
 (☞p.125)

(◀▶) Displays the previous or next image in single-image display. (☞p.36)

Frame forwards, frame reverses, fast forwards and reverses a movie during playback. (☞p.125)

Fast forwards and reverses a voice recording during playback. (☞p.147)

- (▼) Rotates the image. (☞p.36)  
Stops a movie or voice recording during playback.  
(☞p.125, p.147)
- (▲▼◀▶) Moves the display area of the enlarged image. (☞p.119)  
Selects the image in nine-image display and the folder in folder display. (☞p.117)

### ⑤ **OK button**

Changes the information displayed on the LCD monitor. (☞p.121)  
Select or unselect the checkbox for deleting an image in nine-image display. (☞p.129)

### ⑥ **🗑 button**

Deletes the image displayed on the LCD monitor. (☞p.127)

### ⑦ **DPOF button**

Sets the items for DPOF printing of images. (☞p.139)

### ⑧ **🔒 button**

Protects images from deletion. (☞p.131)

### ⑨ **▶ button**

Switches to Capture mode in single-image display. (☞p.35)  
Returns enlarged image display, rotated image display or nine-image display to single-image display. (☞p.117)  
Displays nine-image display for the folder selected in folder display.  
(☞p.118)

### ⑩ **Fn button**

Records a voice memo for a still picture. (☞p.148)

### ⑪ **MENU button**

Displays the [▶ Playback] menu. (☞p.42)

# Using the Menu

When you press the **MENU** button, a menu appears on the LCD monitor. The menu varies depending on the camera mode. You can set functions, save the settings and change the camera settings on these menus.

## How to Use the Menu

A guide to available button operations appears on the LCD monitor during menu operation.

3

Common Operations

Ex.) To set the [Quality Level] on the [Rec. Mode] menu

### 1 Press the MENU button in Capture mode.

The [Rec. Mode] menu appears.

### 2 Press the four-way controller (▼).

You can choose an item.

### 3 Press the four-way controller (▼).

The frame moves to [Quality Level].

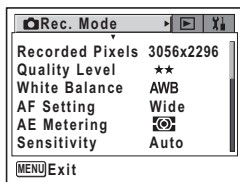

### 4 Press the four-way controller (▶).

A pull-down menu appears with the menu items that can be selected.

The pull-down menu displays only those items that can be selected with the current camera settings.

For example, when Drive mode is set to , the pull-down menu for [Quality Level] displays [★★★], [★★] and [★], but it does not display [TIFF] because it cannot be selected in this Drive mode.

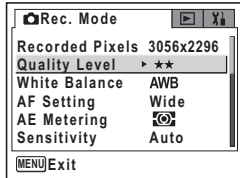

### 5 Use the four-way controller (▲▼) to change the setting.

The quality level changes each time the four-way controller (▲▼) is pressed.

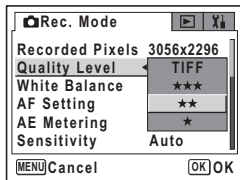

### To Save the Setting and Start Taking Pictures

#### 6 Press the shutter release button halfway or turn the mode dial.

The setting is saved and the screen returns to capture status. When the shutter release button is pressed fully, the setting is saved and the picture is taken.

### To Save the Setting and Begin Playback of Images

#### 6 Press the button.

The setting is saved and the screen returns to playback status.

### To Save the Setting and Continue with Menu Operations

#### 6 Press the OK button or four-way controller (◀).

The setting is saved and the screen returns to that in Step 3.



### To Cancel the Changes and Continue with Menu Operations

#### 6 Press the MENU button.

The changes are canceled and the screen returns to that in Step 3.

The **MENU** button functions differ depending on the screen. Refer to the guide indications.

 Exit : Save the current setting, exit the operation and return to the original screen (Capture or Playback mode).

  : Save the current setting and return to the main menu screen.

 Cancel : Cancel the current selection, exit the operation and return to the original screen (Capture or Playback mode).

## Example of Menu Operation

Press the **MENU** button during taking a picture and the [Rec. Mode] menu appears. Press the **MENU** button during playback and the [Playback] menu appears.



**MENU**

[Menu selection]

You can also use the front lever to change the menu.

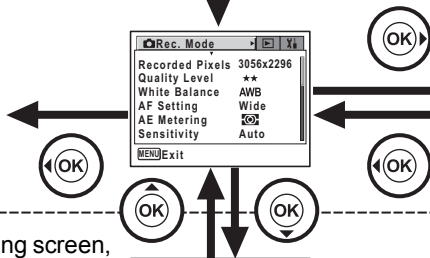

In a pull-down menu or setting screen,

- press the shutter release button to go to Capture mode.
- press the [▶] button to go to Playback mode.

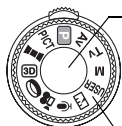

Shutter release button  
press halfway

Mode dial  
switching

Change the setting and go to Capture mode

Caution

- Press the **OK** button or the four-way controller (◀) when a pull-down menu is displayed to return to the menu item selection screen.
- Press the **MENU** button when a pull-down menu is displayed to cancel the setting.

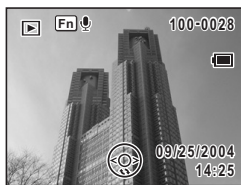

**MENU**

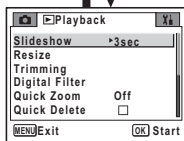
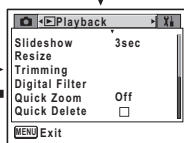

**MENU** or **OK**

Change the setting and go to the previous mode



Change the setting and go to the Playback mode

## Menu List

This displays the items that can be set with the menus and provides descriptions of each item. See the additional default setting list (p.179) to choose whether you want the settings saved when the camera is turned off and whether you want the settings returned to the defaults when the camera is reset.

### [📷 Rec. Mode] Menu

This menu shows the functions related to taking still pictures and recording movies.

Item	Description	Page	
Recorded Pixels	For selecting the number of pixels of still pictures	p.91	
Quality Level	For selecting the compression rate of still pictures	p.93	
White Balance	For adjusting the color balance according to the light conditions	p.95	
AF Setting	Focusing Area	For changing the area of the autofocus	p.97
	AF Mode	For selecting the autofocus mode	p.97
	Focus Limiter	For limiting the lens movement area according to conditions	p.98
	Aux. AF Light	For using the auxiliary AF light (redish orange) when the subject is dark and difficult to focus on using autofocus	p.98
AE Metering	For setting the metering method to determine the exposure	p.100	
Sensitivity	For setting the sensitivity	p.101	
Flash Exp. Comp.	For increasing or decreasing the flash intensity	p.89	
Auto Bracket	For automatically changing the shooting conditions	p.63	
Interval Shoot	For continuous shooting of a set number of pictures at a set interval	p.66	
Movie	Recorded Pixels	For selecting the number of pixels	p.111
	Color Mode	For selecting the color filter	p.112
	Frame Rate	For setting the number of frames taken per second	p.113
	Time-Lapse Movie	For setting the frame rate when recording time-lapse movies	p.114
3D Mode	For taking 3D pictures	p.78	
Digital Zoom	For taking digital zoom pictures	p.58	
Instant Review	For setting the Instant Review time	p.102	
Memory	For choosing whether to save the set values of the shooting function or return to the defaults when the camera is turned off	p.107	
Image Tone	For setting the basic image tone	p.103	
Sharpness	For setting the image sharpness	p.104	
Saturation	For setting the color saturation	p.105	
Contrast	For setting the image contrast	p.106	



## [▶ Playback] Menu

Item	Description	Page
Slideshow	For playing back recorded images one after another	p.123
Resize	For changing the size of images	p.133
Trimming	For deleting the unneeded part of a picture	p.135
Digital Filter	For creating a color filter effect using red, blue, green filters etc.	p.137
Quick Zoom	For playing back images at the set zoom size by pressing the Zoom/⏏/Q button only once	p.120
Quick Delete	For displaying the Delete screen with [Delete] highlighted when [On] is selected	p.128
Alarm	For setting the alarm to ring and display an image at a specific time	p.166



## [⚙️ Set-up] Menu

Item	Description	Page
Format	For formatting SD Memory Cards	p.150
Sound	For adjusting the playback volume and settings of the start-up sound, shutter sound, key operation sound and self-timer sound	p.152
Date Adjust	For adjusting the date, time and date and time styles	p.151
World Time	For setting the world time	p.154
Language/言語	For changing the language in which menus and messages appear	p.155
Folder Name	For setting the folder name with the date setting	p.156
Start-up Screen	For displaying an image as the start-up screen when the camera is turned on	p.157
DISPLAY	For selecting the information displayed on the LCD monitor	p.158
Brightness Level	For changing the brightness of the LCD monitor	p.159
Video Out	For setting the output format to the TV monitor	p.160
USB Connection	For changing the USB connection mode	p.161
Sleep Timeout	For setting the power-saving function	p.162
Auto Power Off	For turning off the power automatically after a fixed time	p.163
Fn Setting	For setting up the functions for the four-way controller	p.164
USER Setting	For registering and saving shooting modes or functions you use most frequently	p.53
Reset	For returning the settings other than the date adjust, language and world time to defaults	p.163

## Selecting a Shooting Mode



There are various ways of capturing images, from modes where the camera automatically sets the shooting functions to obtain the best pictures, to modes where settings are made manually to achieve a particular effect.

### Shooting Modes

<b>PICT</b>	Picture mode	There are 12 Picture modes to choose from. The camera selects the optimal exposure, white balance, etc. according to the shooting conditions. This mode lets you take pictures in a variety of situations.	p.55
<b>P</b>	Program mode	This is the basic picture-taking mode. It offers a wide range of camera functions for you to enjoy.	p.49
<b>Av</b>	Aperture Priority mode	This mode lets you set the aperture manually and the camera automatically selects the shutter speed.	p.50
<b>Tv</b>	Shutter Priority mode	This mode lets you set the shutter speed manually and the camera automatically adjusts the aperture.	p.51
<b>M</b>	Manual mode	This mode lets you set the shutter speed and aperture manually.	p.52
<b>USER</b>	User mode	Lets you take pictures using the functions and settings registered in advance in User mode.	p.53
	Movie mode	Lets you record movie and sound.	p.109
	Digital Filter mode	Lets you take pictures with an artistic feel by adding a digital filter.	p.74
<b>3D</b>	3D Image mode	Lets you take 3D pictures.	p.77
	Panorama Assist mode	Lets you overlap the edges of your images so that they can be joined to form a panorama picture using the software supplied with the camera.	p.75

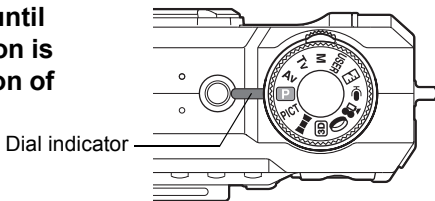
- 1 Turn the mode dial until the desired mode icon is located at the position of the dial indicator.



-  is the mode for recording sound. (p.146)
-  is the mode for using the camera as a digital exposure metering. (p.169)

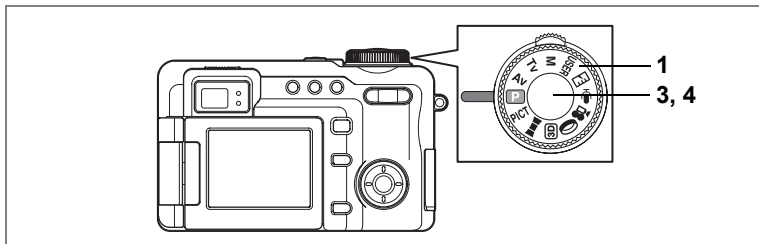

P

## Letting the Camera Set the Exposure (Program Mode)

In **P** (Program mode), the camera automatically sets the shutter speed and aperture for taking still pictures. However, you can select other functions such as the Flash mode or Continuous Shooting mode.

- 1 Set the mode dial to **P**.**
- 2 Set the functions you want to use.**

Refer to "Setting the Shooting Functions" (pp.84 - 106) for details of how to set the functions.

- 3 Press the shutter release button halfway.**

The focus frame turns green if the subject is in focus.

When the subject is in focus, the aperture and shutter speed appear.

- 4 Press the shutter release button fully.**

The picture is taken.



The front lever can be used to adjust the exposure. (p.59)

Taking Still Pictures p.32

4

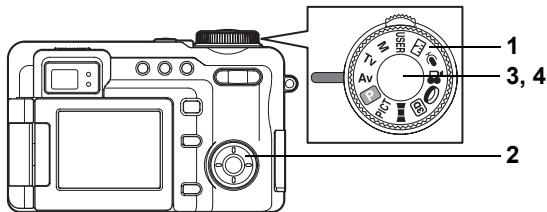

Av

## Aperture Priority Shooting

In this mode, you can set the aperture manually. The camera automatically sets the shutter speed to obtain the optimal exposure at the aperture you have chosen. Decreasing the aperture will produce a picture with a blurred background. Increasing the aperture will produce a picture in which both the foreground and the background are in focus. Use this function when you want to intentionally change the focusing range (depth of field).

- 1 Set the mode dial to Av.**
- 2 Use the four-way controller (▲▼) to change the aperture.**

Pressing ▲ increases the aperture and pressing ▼ reduces the aperture.

- 3 Press the shutter release button halfway.**

The camera adjusts the shutter speed accordingly.

If the appropriate exposure cannot be obtained, the shutter speed displayed on the LCD monitor turns red.

The focus frame turns green if the subject is in focus.

- 4 Press the shutter release button fully.**

The picture is taken.



Total recording time will be longer when the picture is taken at a slower shutter speed, because the noise reduction function activates to reduce picture noise.

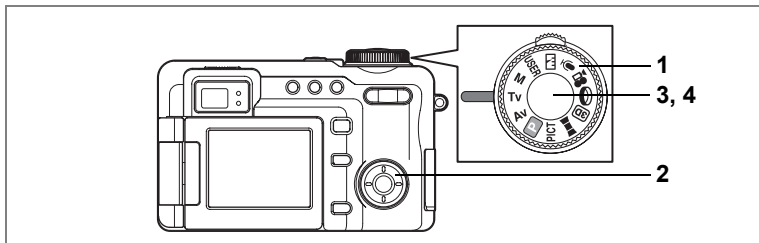

Tv

## Shutter Priority Shooting

In this mode, you can set the shutter speed manually. The camera automatically sets the aperture to obtain the optimal exposure at the shutter speed you have chosen. Use this mode when you want to emphasize movement by setting a slow shutter speed to take a moving subject, or when you want to set a fast shutter speed in dim light to prevent camera shake.

- 1 Set the mode dial to Tv.**
- 2 Use the four-way controller (◀▶) to change the shutter speed.**

Pressing ▶ reduces the speed and pressing ◀ increases the speed.

- 3 Press the shutter release button halfway.**

The camera adjusts the aperture accordingly.

If the appropriate exposure cannot be obtained, the aperture displayed on the LCD monitor turns red.

The focus frame turns green if the subject is in focus.

- 4 Press the shutter release button fully.**

The picture is taken.



- Total recording time will be longer when the picture is taken at a slower shutter speed, because the noise reduction function activates to reduce picture noise.
- In Tv mode, the shutter speed can be set up to approx. 1/1000 seconds. (In Auto, it can be set up to approx. 1/2000 seconds.)
- The set shutter speed is displayed as the default when the camera is turned on the next time in the Tv mode or M mode.

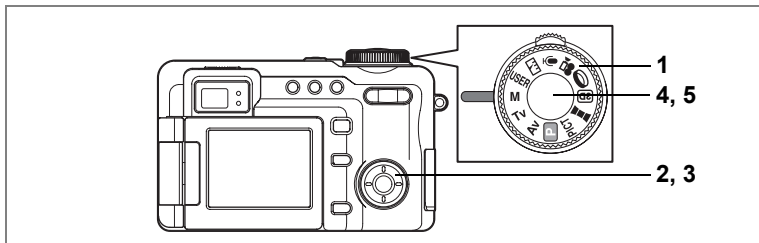

**M**

## Manual Shooting

In this mode, you can set the shutter speed and aperture manually. This mode allows you to produce different creative effects in your pictures.

4

Taking Pictures

- 1 Set the mode dial to M.**
- 2 Use the four-way controller (▲▼) to change the aperture.**
- 3 Use the four-way controller (◀▶) to change the shutter speed.**

Pressing ▲ increases the aperture and pressing ▼ reduces the aperture.

Pressing ▶ reduces the speed and pressing ◀ increases the speed. If the exposure is unsuitable, the range appears on the exposure bar.

- 4 Press the shutter release button halfway.**

The focus frame turns green if the subject is in focus.

- 5 Press the shutter release button fully.**

The picture is taken.



- Total recording time will be longer when the picture is taken at a slower shutter speed, because the noise reduction function activates to reduce picture noise.
- In **M** mode, Auto flash and (Auto + Red-eye Reduction) cannot be selected.
- In **M** mode, the front lever cannot be used to adjust the exposure.

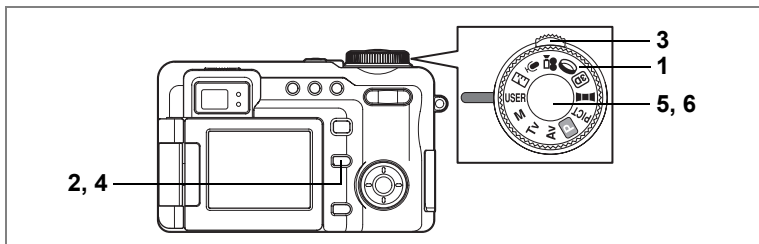

USER

## Using Preset Function Settings (User Mode)

Register shooting modes or functions that you use frequently and then align the mode dial to **USER** to quickly take pictures using your preferred settings.

Three User modes (USER1, USER2 and USER3) can be registered. (p.54)

### 1 Set the mode dial to **USER**.

The current User mode is indicated at the top left of the screen. To take pictures with this User mode, go to Step 5 below.



### 2 Press the **Fn** button.

The Fn guide screen appears.

### 3 Press the front lever to the right or left to select a user mode.

### 4 Press the **Fn** button.

The camera is ready to take pictures in the selected User mode.

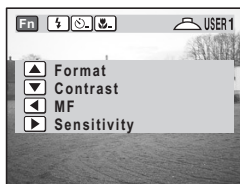

### 5 Press the shutter release button halfway.

The focus frame turns green if the subject is in focus.

### 6 Press the shutter release button fully.

The picture is taken.

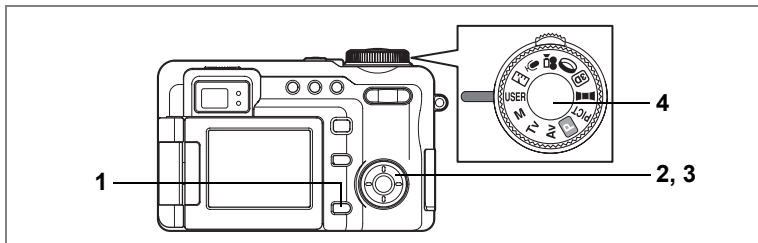

## Registering Functions to a User Mode

### 1 Press the MENU button in the User mode.

The User menu appears. Refer to p.182 for the functions that can be registered in the user modes.

### 2 Use the four-way controller (◀▶) to select USER1, USER2 or USER3.

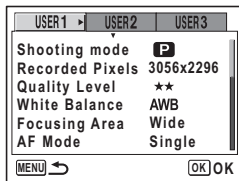

### 3 Use the four-way controller (▲▼) to choose an item.

Set the desired setting for each item. Refer to each item for the setting procedure.

### 4 Press the shutter release button halfway.

The User setting is saved and the screen returns to capture status. Refer to Step 6 of “How to Use the Menus” (p.43) for other operations after the settings have been made.















- The User menu in Step 1 above can also be displayed from the [Fn/Set-up] menu.
- Choose one of the following four shooting modes: **P**, **M**, **Tv**, **Av**. All other items are set in the same manner as the normal menus.



## Selecting the Picture Mode According to the Shooting Scene (Picture Mode)

You can select the Picture mode according to the shooting scene.

There are 12 available modes in Picture mode.

	Landscape	Lets you capture the bright colors of landscape views by emphasizing the contours and saturation of green trees, blue sky, etc.
	Surf&Snow	Lets you take bright, vivid pictures of the sea, lakes or snow-covered landscapes in bright sunshine. (Views are vividly reproduced by slightly increasing the contrast.)
	Sunset	Lets you reproduce the beautiful colors of the sunrise or sunset. (Brilliant hues are captured by adjusting the exposure to create a slightly dark, twilight atmosphere and increasing the saturation a little.)
	Flower	Lets you capture the vivid colors of flowers. The brightness of the image is maintained while the background is moderately blurred.
	Autumn colors	Lets you take colorful pictures of trees in autumn.
	Food	Lets you take appetizing pictures of prepared food.
	Portrait	Lets you take portrait shots in natural tones. (Natural skin tone is captured by reducing the contrast.)
	Self-portrait	Lets you take pictures of yourself or include yourself in pictures. (The focus is regulated to take into account the shooting distance (arm's length).)
	Sport	Lets you take sharp pictures of a quickly moving subject, such as at a sporting event.
	Night Scene	Lets you take dark scenes such as night views.
	Night Scene Portrait	Lets you capture evening or night views or take pictures of people against a nightscape. (The camera features a max. slow shutter speed of four seconds and has slow synchronization and noise reduction functions.)
	Fireworks	Lets you take bright photos of fireworks.

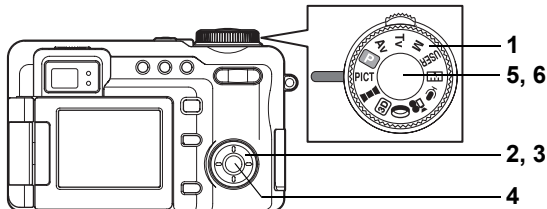

- 1 Set the mode dial to PICT.**
- 2 Press the four-way controller (▲▼).**  
The Picture mode options screen appears.

- 3 Use the four-way controller (▲▼◀▶) to choose a Picture mode.**

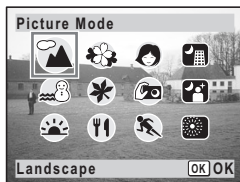

- 4 Press the OK button.**  
The Picture mode is selected and the screen returns to capture status.

- 5 Press the shutter release button halfway.**  
The focus frame turns green if the subject is in focus.

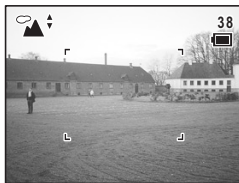

- 6 Press the shutter release button fully.**  
The picture is taken.



The shutter speed is slower when taking pictures of dark scenes. To prevent camera shake, secure the camera on a tripod or other surface.



- In Picture mode, the saturation, contrast, sharpness and white balance are automatically set to the optimal settings for each mode and cannot be changed manually.
- Total recording time will be longer when the picture is taken at a slower shutter speed, because the noise reduction function activates to reduce picture noise.

Using the Shutter Release Button p.33

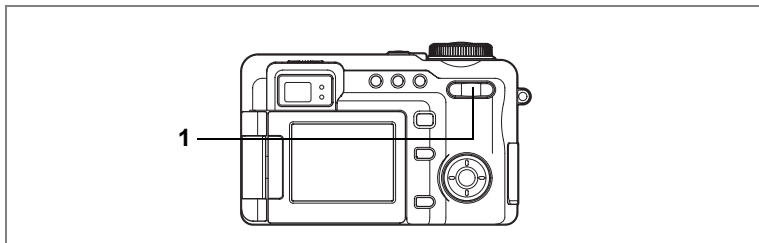

USER M Tv Av P PICT ■■■ 3D ○

## Using the Zoom

You can use the zoom to change the shooting area.

### 1 Press the Zoom/▲▲▲/▲ button in Capture mode.

▲ (Tele) : enlarges the subject

▲▲▲ (Wide) : enlarges the area captured by the camera

The zoom bar indicates the current level of magnification.

When the digital zoom function is disabled, you can take pictures at up to five times magnification using the optical zoom. When the digital zoom function is set to [×8], you can combine the digital zoom with the optical zoom to give a maximum zoom magnification equivalent to 40 times.

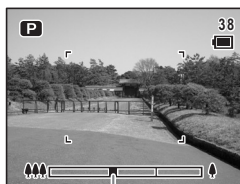

Zoom bar

↓ Press toward ▲

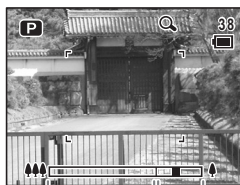

Optical zoom range      Digital zoom range



- You are recommended to use a tripod to prevent camera shake when taking pictures at a high magnification rate.
- Only the digital zoom can be used during movie recording.
- With the Drive mode set to Remote Control, the remote control E (optional) can be used to operate the zoom. (p.72)

## Setting the Digital Zoom

The default setting for the digital zoom is [ $\times 2$ ]. To take pictures at the maximum magnification, set the digital zoom to [ $\times 8$ ] and to take pictures using only the optical zoom, set the digital zoom to [Off].

- 1 Press the MENU button in Capture mode.**  
The [📷 Rec. Mode] menu appears.
- 2 Use the four-way controller (▲▼) to select [Digital Zoom].**
- 3 Press the four-way controller (▶).**  
A pull-down menu appears.
- 4 Use the four-way controller (▲▼) to select [ $\times 2$ ], [ $\times 8$ ], [Off].**
- 5 Press the shutter release button halfway.**

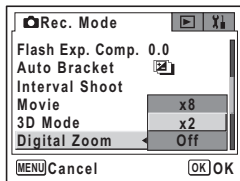

The digital zoom function setting is saved and the screen returns to capture status. Refer to Step 6 of “How to Use the Menus” (p.43) for other operations after the setting has been made.

Saving the Digital Zoom Function Setting p.107

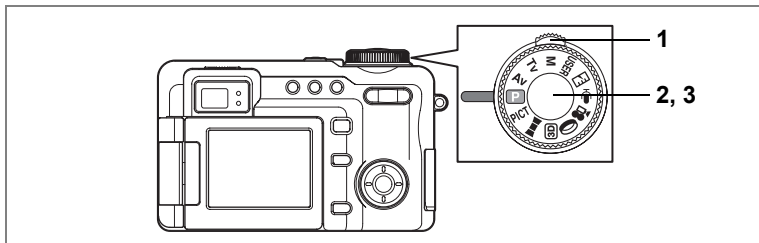

USER Tv Av P PICT ■■■ 3D 0

## Setting the Exposure (EV Compensation)

You can adjust the overall brightness of the picture. Use this function to take pictures that are intentionally overexposed or underexposed.

- 1 Press the front lever to the right or left in Capture mode.**

You can change the EV setting.  
 To brighten, select a positive (+) value. To darken, select a negative (-) value.  
 You can choose the EV setting in the range of -2.0 EV to +2.0 EV in 1/3 EV steps.



EV Compensation

- 2 Press the shutter release button halfway.**

The focus frame turns green if the subject is in focus.

- 3 Press the shutter release button fully.**

The picture is taken.

Saving the EV Compensation Value p.107

Auto Bracketing p.63

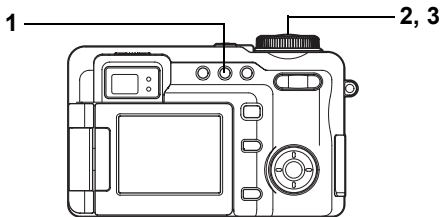

PICT Tv Av M USER

## Continuous Shooting (Continuous Shooting Mode)

4

Pictures are taken continuously while the shutter release button is pressed.

**1 Press the button in Capture mode to display on the LCD monitor.**

**2 Press the shutter release button halfway.**

The focus frame turns green if the subject is in focus.

**3 Press the shutter release button fully.**

Pictures are taken continuously while the shutter release button is pressed.

Shooting stops when you take your finger off the shutter release button.



- The flash will not discharge in Continuous Shooting mode.
- Continuous shooting is not possible in , and modes, or when digital filter is set to SOFT.
- Continuous shooting is not possible when the quality level is set to TIFF. Also, in Continuous Shooting mode, the TIFF quality level cannot be selected.



- You can continue shooting until the memory capacity of the SD Memory Card is full.
- The interval will vary according to the Recorded Pixels and Quality Level settings.
- The focus, exposure and white balance are locked with the first image.

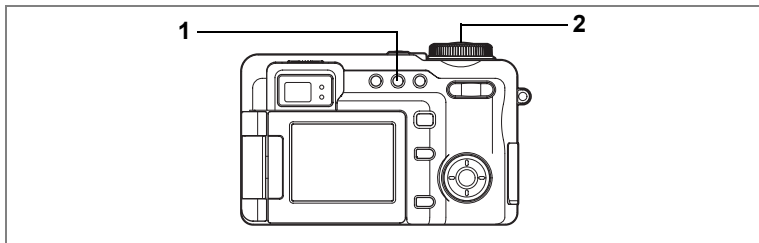

USER M Tv Av P PICT

## Using the Self-Timer

In Self-Timer mode, the picture is taken ten seconds or two seconds after the shutter release button is pressed. Use the ten-second self-timer when you want to be included in a group picture. Use the two-second self-timer to avoid camera shake when you press the shutter release button.

**1 Press the button in Capture mode to display on the LCD monitor.**

Depending on the previous setting, or appears.

**2 Press the shutter release button fully.**

The picture is taken approximately ten seconds after the shutter release button is pressed. The self-timer lamp lights for about seven seconds, then blinks for about three seconds.

The self-timer lamp blinks for about two seconds after the shutter release button is pressed and the picture is taken.



Focusing may be compromised if you move the camera while the self-timer lamp is blinking when taking still pictures. (p.84)



- In mode, recording movies will start after ten seconds (or two seconds).
- Press the shutter release button halfway while the self-timer is engaged to cancel the self-timer. Press the shutter release button fully to reset the self-timer to ten seconds (or two seconds).

Troubleshooting p.187

## Switching between and

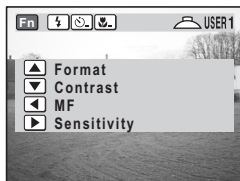

- 1 Press the Fn button when  () is displayed on the LCD monitor.**

The Fn guide screen appears.





- 2 Press the   button.**

The Self-Timer menu appears.

- 3 Use the four-way controller ( ) to select [10sec] or [2sec].**

- 4 Press the OK button.**

 or  is selected and the screen returns to capture status.

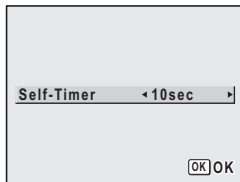



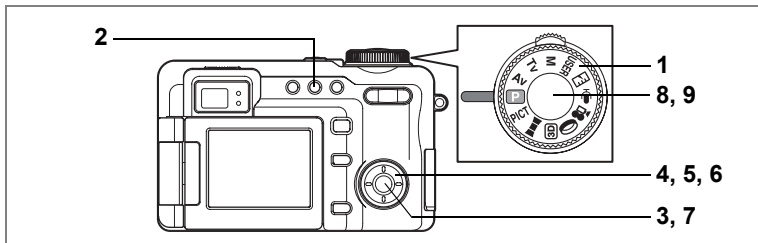

USER M Tv Av P PICT

## Automatically Changing the Shooting Conditions (Auto Bracket)

Auto bracketing can be used to automatically vary settings such as the exposure and white balance over a series of three shots when the shutter release button is pressed. This ensures that you are able to get the best shots.

### Auto Bracket Settings

	Exposure	Pictures are taken in the following sequence: normal, underexposed (dark), overexposed (bright). Choose the bracketing steps from 0.3, 0.7, 1.0, 1.3, 1.7, 2.0. (see p.59)
	White Balance	Conditions change in the following sequence: normal, red tinge (low color temperature), blue tinge (high color temperature). Choose the bracketing steps from 1, 2, 3, 4, 5. (see p.95)
	Saturation	Conditions change in the following sequence: Current Setting, - (low), + (high). (see p.105)
	Sharpness	Conditions change in the following sequence: Current Setting, - (soft), + (hard). (see p.104)
	Contrast	Conditions change in the following sequence: Current Setting, - (low), + (high). (see p.106)

**1** Set the mode dial to a mode other than or .

**2** Press the button to display .

The icon corresponding to the current setting appears, and then the setting appears for approx. five seconds. To take pictures with the current setting, go to Step 8 below.



### 3 Press the **OK** button while the setting is displayed.

The Auto bracketing options screen appears.

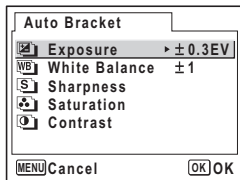

### 4 Use the four-way controller (▲▼) to choose the shooting conditions.

### 5 Press the four-way controller (▶) for Auto Bracket settings [A] or [WB].

A pull-down menu appears.

### 6 Use the four-way controller (▲▼) to choose the bracketing steps.

### 7 Press the **OK** button.

The camera is ready to take pictures. The function chosen for auto bracketing appears on the LCD monitor.



### 8 Press the shutter release button halfway.

The focus frame turns green if the subject is in focus.

### 9 Press the shutter release button fully



- Three pictures are taken in succession when [A] is selected and the shutter release button is pressed down fully in Step 9.
- Only one picture is taken when any other auto bracketing option is selected and the shutter release button is pressed down fully in Step 9, and the camera creates a series of three shots internally.
- Auto bracketing cannot be used with [S] in [M], [A], [S], [M], [A], [S], [M] and PICT modes, or when digital filter is set to SOFT.
- Auto bracketing cannot be used when the quality level is set to TIFF. Also, in Auto Bracket mode, the TIFF quality level cannot be selected. (p.93)



- The Auto Bracket menu in Step 3 above can also be displayed from the [Rec. Mode] menu.
- With the exception of the shooting conditions selected for auto bracketing, the second and third pictures are taken under the same conditions as the first picture.
- Press the **MENU** button twice in Step 2 or 7 to return to Step 1 and change the setting.

### Setting + () or + ()

Auto bracketing can be used with the self-timer or the remote control unit (optional).

#### 1 Press the Fn button when is displayed on the LCD monitor.

The Fn guide screen appears.

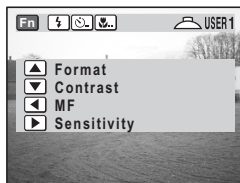

#### 2 Press the button.

The Drive mode screen appears.

#### 3 Use the four-way controller (◀▶) to select [, + ()] or [+ ()].

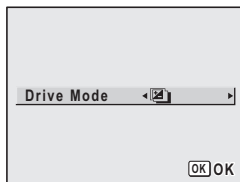

#### 4 Press the OK button.

The camera is ready to take pictures.

When + () is selected, auto bracketing can be used with the self-timer.

When + () is selected, auto bracketing can be used with remote control.



The countdown time for the self-timer and remote control are according to the self-timer and remote control settings, respectively. (p.61, p.72)

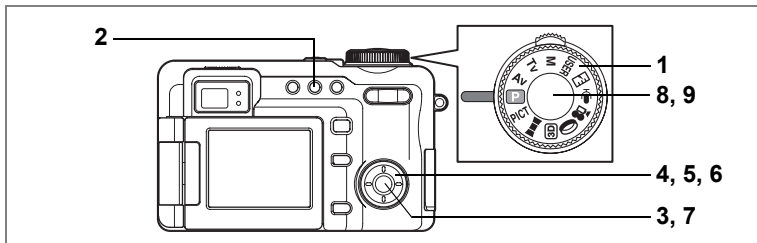

USER M Tv Av P PICT 0

## Taking Pictures at Fixed Intervals (Interval Shooting)

4

Taking Pictures

A set number of pictures can be automatically taken from a set time and for a set interval.

Interval	10 seconds to 99 minutes	Interval shooting can be set at intervals of 10 seconds to 4 minutes in units of 1 second, and intervals of 4 minutes to 99 minutes in units of 1 minute. Intervals of less than 10 seconds cannot be set.
Number of shots	2 to 99 pictures	—
Start time	0 minutes to 23 hours and 59 minutes	Can be set in units of 1 minute. If the start time is set to 0 min., the first picture will be taken as soon as the shutter release button is pressed.

**1** Set the mode dial to a mode other than or .

**2** Press the button in Capture mode to display on the LCD monitor.

The current interval shooting setting appears for approx. five seconds. To take pictures with the current setting, go to Step 8 below.

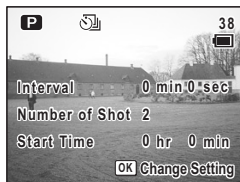

### 3 Press the OK button while the setting is displayed.

The Interval Shooting menu will be displayed and [Interval] will be framed.

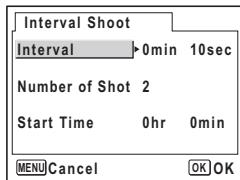

### 4 Set the interval time.

- 1 Press the four-way controller (▶).
- 2 Use the four-way controller (▲ ▼) to change the minutes, then press (▶).
- 3 Use the four-way controller (▲ ▼) to change the seconds, then press (▶).

The frame returns to [Interval].

### 5 Set the number of shots.

- 1 Use the four-way controller (▲ ▼) to select [Number of Shot].
- 2 Press the four-way controller (▶).
- 3 Use the four-way controller (▲ ▼) to change the number of shots, then press (▶).

The frame returns to [Number of Shot].

### 6 Set the time to start shooting.

- 1 Use the four-way controller (▲ ▼) to select [Start Time].
- 2 Press the four-way controller (▶).
- 3 Use the four-way controller (▲ ▼) to change the hours, then press (▶).
- 4 Use the four-way controller (▲ ▼) to change the minutes, then press (▶).

The frame returns to [Start Time].

### 7 Press the OK button.

The camera is ready to take pictures.

### 8 Press the shutter release button halfway.

The focus frame turns green if the subject is in focus.





## 9 Press the shutter release button fully.

Interval shooting starts.

Between shots, the camera turns off. The remaining number of pictures and interval time will be displayed on the LCD monitor when you press the power switch on during standby.

If you press the **MENU** button, the message [Stop interval shooting?] will be displayed. To cancel interval shooting, press the **OK** button.



- Interval shooting is not possible in ,  and  modes.
- Interval shooting cannot be used when the quality level is set to TIFF. Also, in interval shooting, the TIFF quality level cannot be selected.
- The Interval Shooting menu in Step 3 above can also be displayed from the [ Rec. Mode] menu.

4



- In interval shooting, all pictures are taken under the same shooting conditions as the first picture. Items set to Auto are stored as Auto settings. When the focus mode is set to AF, the autofocus is adjusted for each shot.
- Interval shooting stops and the camera turns off automatically when the SD Memory Card runs out of memory space.
- Press the **MENU** button twice in Step 2 or 7 to return to Step 1 and change the setting.

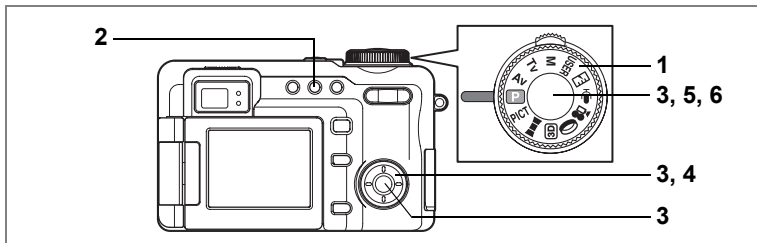

USER M Tv Av P PICT

## Superimposing One Picture on Top of Another (Multiple Exposure Mode)

Pictures can be taken with multiple images superimposed on each other. When used together with interval shooting, pictures are taken with the set number of images superimposed over the first image.



Multiple exposure shooting is not possible when the quality level is set to TIFF. Also, in Multiple Exposure mode, the TIFF quality level cannot be selected.

**1** Set the mode dial to a mode other than , , , or .

**2** Press the button in Capture mode to display on the LCD monitor.



When the camera has images that have been recorded, the screen for selecting the initial image, to which other images are superimposed, appears. Go to Step 3.

When there are no still images in the camera, [Base Image Shooting] appears and the camera returns to Capture mode. Go to Step 3'.

**3** Use the four-way controller ( ) to choose the base image and press the OK button.

The selected image will appear in transparent form on the LCD monitor.

### 3' Press the shutter release button to take the base image.

The selected image will appear in transparent form on the LCD monitor.

### 4 Aim the camera at your subject and choose the exposure method with the four-way controller (▲▼).

☐ : Priority is given to the brighter image.

● : Priority is given to the darker image.

⊙ : The average exposure is obtained.

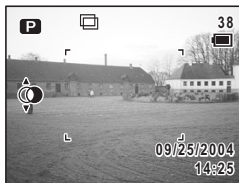

### 5 Press the shutter release button halfway.

The focus frame turns green if the subject is in focus.

### 6 Press the shutter release button fully.

The Instant Review screen will be displayed and you will be asked whether you want to continue shooting.

If you select [Continue] and press the **OK** button, the picture you have just created will be played back enabling you to add another image.

The superimposed image is saved with a name separate from that of the original image.



## Setting + () or + ()

A multiple exposure picture is taken with the self-timer or the remote control unit (optional).

### 1 Press the Fn button when is displayed on the LCD monitor.

The Fn guide screen appears.

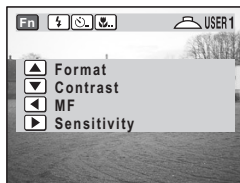

### 2 Press the button.

The Drive mode screen appears.

### 3 Use the four-way controller ( ) to select [, [+ ()] or [+ ()].

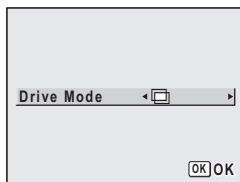

### 4 Press the OK button.

The camera is ready to take pictures.

When + () is selected, a multiple exposure picture is taken with the self-timer.

When + () is selected, a multiple exposure picture is taken with remote control.

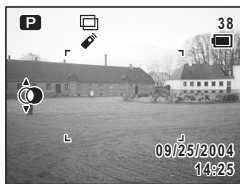

The countdown time for the self-timer and remote control are according to the self-timer and remote control settings, respectively. (p.61, p.72)

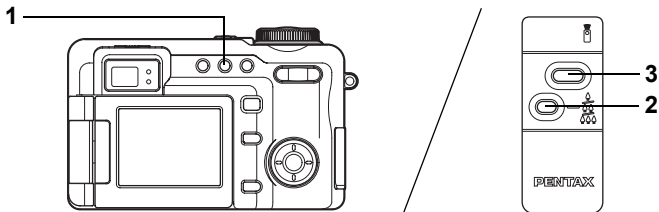



Remote control unit E

USER M Tv Av P PICT 0 0

## Using the Remote Control Unit (optional)

You can switch the Drive mode to Remote Control mode and take pictures using the remote control unit for Pentax cameras (optional). The remote control receiver is on the front of the camera. Operate the remote control unit toward the camera lens.

### 1 Press the button in Capture mode to display on the LCD monitor.

Depending on the previous setting,  or  appears.

The self-timer lamp blinks slowly and the camera is ready to take the picture.



### 2 Press the zoom button to adjust the zoom (for remote control unit E).

The zoom position changes each time the zoom button is pressed in the following sequence: tele → middle → wide

### 3 Press the shutter release button fully on the remote control unit.

 The picture is taken immediately.

 The self-timer lamp blinks quickly and the picture is taken after approximately three seconds.



Focusing may be compromised if you move the camera while the self-timer lamp is blinking.



- The buttons on the camera can be used in the normal way.
- Ensure that the remote control unit is no more than 4 m (13 ft.) away from the front of the camera.

## Life of the Battery for the Remote Control Unit

A signal can be sent from the remote control unit to the camera approximately 30,000 times. Contact your nearest PENTAX customer service center if the battery needs changing. (A charge is made for changing the battery.)

### Switching between and

- 1 Press the Fn button when  () is displayed on the LCD monitor.**

The Fn guide screen appears.

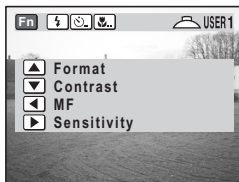



- 2 Press the  button.**

The remote control screen appears.

- 3 Use the four-way controller ( ) to select [0 sec] or [3 sec].**

- 4 Press the OK button.**

 or  appears and the screen returns to capture status.

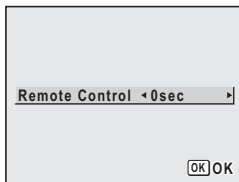

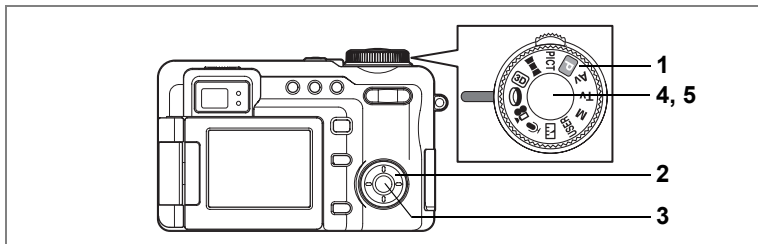

0

## Taking Pictures with Digital Filters (Digital Filter Mode)

4

You can take pictures using a variety of digital filters.

### 1 Set the Mode dial to 0.

The previously selected digital filter appears.

### 2 Use the four-way controller (▲▼) to choose a digital filter.

You can choose from nine color filters: B&W, Sepia, Red, Pink, Purple, Blue, Green, Yellow and SOFT.

### 3 Press the OK button.

The digital filter is selected and the screen returns to capture status.

### 4 Press the shutter release button halfway.

The focus frame turns green if the subject is in focus.

### 5 Press the shutter release button fully.

The picture is taken.





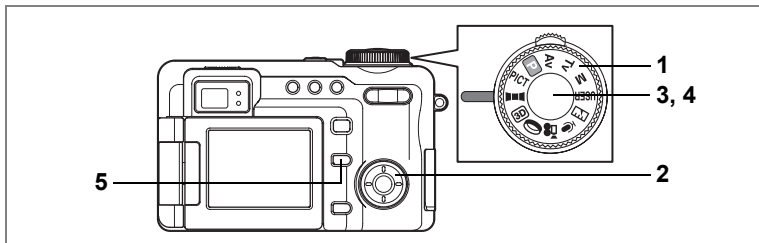

- These digital filters are for use when taking still pictures. In Movie mode, you can only choose B&W or Sepia for [Color Mode] on the Movie screen on the [Rec. Mode] menu. (p.112)
- The digital filter effect can also be added after taking a still picture. (p.137)
- Continuous shooting and auto bracketing are not possible when SOFT is selected.



## Taking Panorama Pictures (Panorama Assist)

You can take a number of images and join them together to form a panorama picture. The panorama software (ACDSee for PENTAX) supplied with the camera on the CD-ROM (S-SW22) and a computer are necessary for joining the images. The Panorama Assist mode enables you to overlap the edges of the images so that they are easier to join together later into a panorama picture.

- 1 Set the mode dial to .**
- 2 Use the four-way controller to choose the direction in which the images will be joined.**

-  : Joins the images at the left.
-  : Joins the images at the right.
-  : Joins the images at the top.
-  : Joins the images at the bottom.

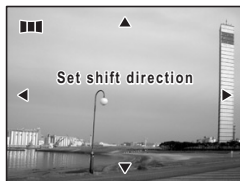

The example shows the images when  is selected.

- 3 Take the first image.**

Press the shutter release button to take the first image. The right edge of the image appears in semi-transparent form on the left of the LCD monitor.

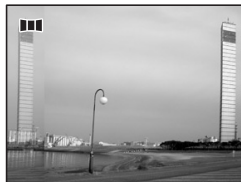

#### 4 Move the camera to the right and take the second image.

Move the camera until the half-transparent image and the actual view overlap and press the shutter release button. Repeat Steps 3 and 4 to take the third and subsequent images.



#### 5 Press the Fn button.

The screen returns to Step 2.

To cancel Panorama assist mode, set the mode dial to any mode other than **■■■**.

**Caution**

- The camera cannot join the images. Use the panorama software supplied with the camera (ACDSee for PENTAX, ACD photostitcher). Refer to the “PC Guide - Enjoying Your Digital Camera Images On Your PC” for instructions on stitching images.
- In Panorama Assist mode, the image is saved as **★★★** (JPEG) even when the quality level is set to TIFF.

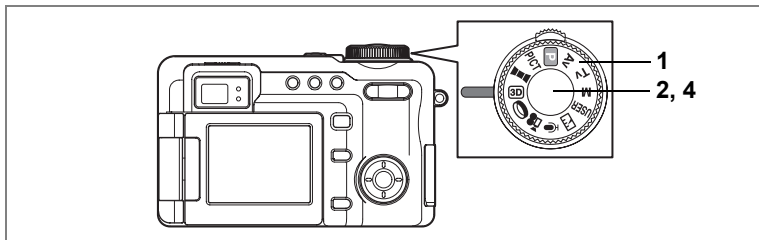

3D

## Taking 3D Pictures (3D Image Mode)

3D pictures can be taken in which two pictures placed side-by-side can be viewed using a special method to produce a three-dimensional image. You can take 3D pictures and view them by the parallel method or cross method. The default setting is [Parallel]. Refer to “Selecting the Viewing Mode” (p.78) for instructions on taking pictures by the cross method.

### 1 Set the mode dial to 3D.

The screen for taking the first image appears on the left half of the LCD monitor.

### 2 Take the first image.

Hold the camera so that the subject is in the middle of the left half of the screen and press the shutter release button. The image appears in the left half of the LCD monitor. The right half of the screen is for taking the second image.

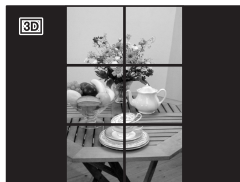

### 3 Move the camera to the right without changing your stance.

### 4 Take the second image.

Make sure that the subject is in the middle of the right half of the screen and press the shutter release button.

To cancel the 3D Image mode, set the mode dial to any mode other than 3D.



In 3D Image mode, the image is saved as ★★★ (JPEG) even when the quality level is set to TIFF.

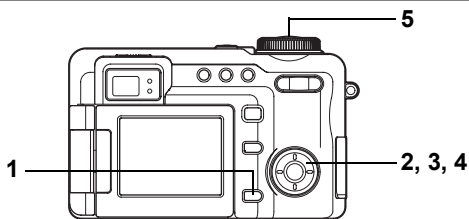

## Selecting the Viewing Mode

### 1 Press the MENU button.

The [Rec. Mode] menu appears.

### 2 Use the four-way controller (▲▼) to select [3D Mode].

### 3 Press the four-way controller (▶). A pull-down menu appears.

### 4 Use the four-way controller (▲▼) to select [Parallel] or [Cross].

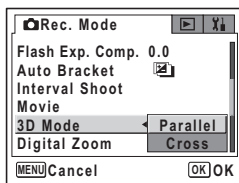

You can view both [Parallel] and [Cross] pictures without the image viewer.

To view pictures with the 3D image viewer (optional), select [Parallel].

### 5 Press the shutter release button halfway.

The 3D Mode setting is saved and the screen returns to capture status. Refer to Step 6 of "How to Use the Menus" (p.43) for other operations after the setting has been made.

## How to Take and View 3D Pictures

As our eyes are positioned about 6 cm (2.4 in.) or 7 cm (2.8 in.) apart, there is a very slight deviation between what we see with our right eye and what we see with our left eye. The difference is processed by our brain to produce a three-dimensional image. This principle is applied to taking and viewing 3D pictures.

A three-dimensional effect will not be achieved if the subject moves before the second image is taken. When taking a 3D picture of a person, ask your subject to stay as still as possible, and then take the second picture as quickly as you can. It is easier to take the picture if you use a tripod or appropriate base.



As a guide, the camera should be moved about 1/40 of the distance between the camera and the subject. For example, if the subject is 3 m (9.8 ft.) away, the distance the camera should be moved will be  $3 \text{ m} \div 40 = 7.5 \text{ cm}$  (3 in.). However, the way people view three-dimensional images differs from person to person. Refer to the table below for a simple guide to how far to move the camera.

Distance to subject	0.1 m (0.3 ft.)	0.3 m (1 ft.)	0.5 m (1.6 ft.)	1 m (3.3 ft.)	3 m (9.8 ft.)	5 m (16.4 ft.)
Camera movement	0.5 cm (0.2 in.)	1 cm (0.4 in.)	1.5 cm (0.6 in.)	2.5 cm (1 in.)	7.5 cm (3 in.)	13 cm (5.1 in.)

3D pictures can be viewed by the [parallel] method where the left and right lines of vision are virtually parallel, as when looking at a distant scene, or the [cross] method where the left and right lines of vision are crossed, as when you cross your eyes. A certain amount of practice may be necessary to view 3D pictures without using the viewer.

### How to View 3D Pictures Using the 3D Image Viewer (Optional)

Print out the pictures so that they are about 11 cm (4.3 in.) or 12 cm (4.7 in.) wide and place the divider of the 3D image viewer in the middle of the two.

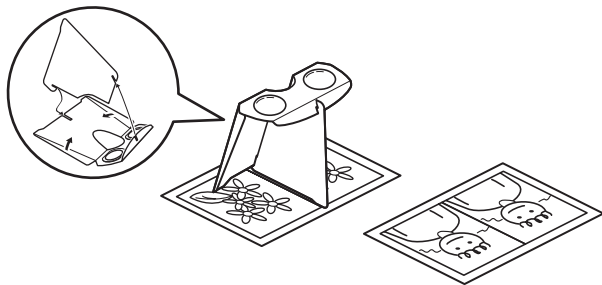

As the distance between the left and right eyes differs from person to person, some people may have difficulty obtaining a three-dimensional effect even when looking at prints that are the same size. It may be especially difficult if the pictures are very large or very small. Try different sizes until the right effect is achieved.



- Never look at the sun through the 3D image viewer.
- Do not leave the 3D image viewer where it is exposed to direct sunlight as this may lead to fire.

## Example of a 3D Picture (Parallel Method)



# Displaying Shooting Information in Capture Mode

The LCD monitor display changes each time you press the **OK** button. You can use Setting 1 and Setting 2 to select the information to be displayed. As the default setting, Setting 1 displays all information and Setting 2 displays no information.

When the histogram (image brightness distribution) appears, bright portions are displayed in red and dark portions are displayed in yellow on the LCD monitor. The horizontal axis of the histogram shows the brightness (darkest at the left end and brightest at the right end) and the vertical axis shows the number of pixels.

## Normal Display

Shooting information appears when the camera is turned on.

- 1 Shooting mode (p.48)
- 2 User mode (p.53)
- 3 Flash mode (p.87)
- 4 Drive mode (pp.60 - 73)
- 5 Focus mode (p.84)
- 6 Card status (p.25)
- 7 Digital zoom display (p.57)
- 8 Focus frame (p.32)
- 9 Number of images remaining
- 10 Battery level indicator (p.16)
- 11 Date and time (p.29)
- 12 EV compensation (p.59)
- 13 Aperture (p.50)
- 14 Shutter speed (p.51)

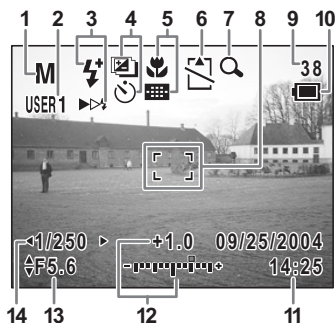

**Setting 1 (full display)**

- 1 White balance (p.95)
- 2 Recorded pixels (p.91)
- 3 Quality level (p.93)
- 4 AE metering (p.100)
- 5 Histogram
- 6 Sensitivity (p.101)
- 7 Dark portions (displayed in yellow)
- 8 Bright portions (displayed in red)

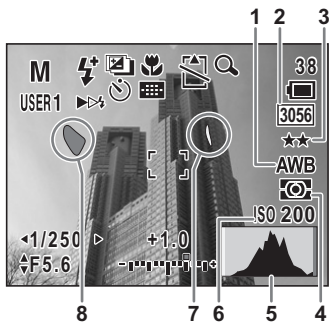
**Setting 2 (no icons)**

No shooting information is displayed.

- The focus frame appears in Autofocus mode.
- When a setting is changed, the setting appears for a few seconds.

**LCD Monitor Off**

(No icons)



LCD monitor off



Normal display



- The LCD monitor cannot be turned off in , , or mode.
- During movie recording, the LCD monitor display cannot be changed by pressing the OK button. The histogram cannot be displayed either during movie recording.

## About the Bright and Dark Portions

When there is an area of the subject that is so bright it appears white, the indicated area blinks red as a warning. Similarly, when there is an area that is so dark it appears black, the indicated area blinks yellow as a warning.

Displaying Shooting Information in Playback Mode  
 p.121

# Setting the Shooting Functions

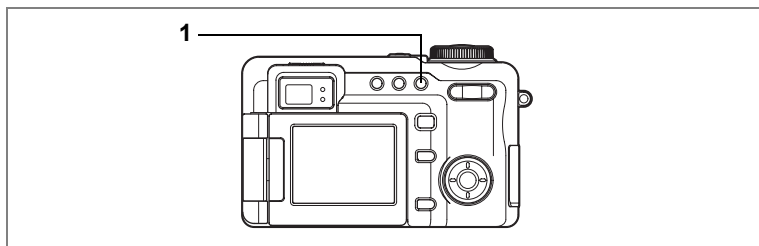

USER M Tv Av P PICT ■■■ 3D 0

## 4 Selecting the Focus Mode

### Focus Modes

(No icon)	Autofocus	The camera focuses on the subject in the focusing area when the shutter release button is pressed halfway. Use this mode when the distance to the subject is more than 60 cm (2 ft.).
	Macro mode	This mode is used when the distance to the subject is approx. 15 cm to 65 cm (6 in. to 2.1 ft.). The camera focuses on the subject in the focusing area when the shutter release button is pressed halfway. This can be set together with
	Super Macro mode	This mode is used when the distance to the subject is approx. 2 cm to 65 cm (0.8 in. to 2.1 ft.). The camera focuses on the subject in the focusing area when the shutter release button is pressed halfway. This can be set together with
	Infinity-Landscape mode	This mode is used for taking distant objects. The flash is set to  (flash off).
MF	Manual Focus mode	This mode lets you adjust the focus manually.
	Focusing Area mode	This mode changes the position of the focusing area. You can select from 11 positions. This can be set together with ,

### 1 Press the MF button in Capture mode.

The focus mode changes each time the button is pressed and the icon appears on the LCD monitor.

The camera is ready to take pictures in the selected focus mode.



- Make sure that the surface of the lens is clean as any dirt on the lens in **s** mode may cause the camera to focus on the dirt rather than on the subject.
- If you take a picture while looking through the viewfinder when the focus mode is set to **M** or **sM**, the range of the resulting picture will differ from what was seen in the viewfinder. Be sure to check the image on the LCD monitor.



- The default setting is Autofocus mode.
- Only the digital zoom can be used in **s** mode.

Saving the Focus Mode **▶**p.107

## Manual Focus

### 1 Press the **M** button in Capture mode to display MF.

The central portion of the screen is magnified twice as large when focusing.

### 2 Press the Zoom/**M** button.

The MF indicator appears on the LCD monitor, indicating the approximate distance to the subject. Using the indicator as a guide, adjust the focus with the Zoom/**M** button.

**M** : for distant focus

**M** : for closer focus

### 3 Press the OK button.

The focus position is set and the screen returns to the normal display.

To set the focus position, you can also press the shutter release button halfway or fully, or wait for at least five seconds.

To readjust the focus, press the **M** button once to return to Step 1 above.

### 4 Press the Zoom/**M** button to adjust the captured area.

When the focus position has been determined, the LCD monitor display returns to the normal picture range and the zoom bar appears in the position where the MF indicator was displayed for focusing.

To enlarge the subject or capture a broader area, press the Zoom/**M** button to adjust the captured range.



MF Indicator

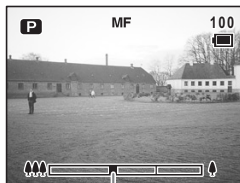





Zoom bar

## Adjusting the Focusing Area

- 1 Press the  **MF** button in Capture mode to display .

The previously selected focusing area appears.

- 2 Use the four-way controller (   ) to choose the focusing area.

Press the  **MF** button to switch to autofocus.

- 3 Press the **OK** button.

The focusing area is fixed in its new position.

To return the focusing area to its original position, press the  **MF** button again.

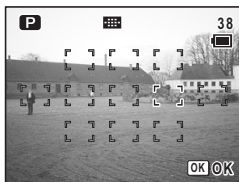

The focusing area appears as a spot when it is being adjusted.

## Using and together



You can change the focusing area in Macro or Super Macro mode.

- 1 Press the **Fn** button in the  and  mode.

The Fn guide screen appears.

- 2 Press the  **MF** button.



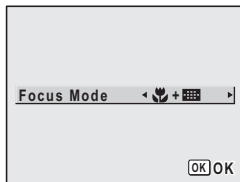

The Focus Mode screen appears.

- 3 Use the four-way controller ( ) to choose the Focus mode combination.



- 4 Press the **OK** button.

The Focusing area screen appears.

- 5 Use the four-way controller (   ) to set the focusing area, and then press the **OK** button.

The camera is ready to take pictures.

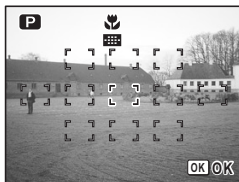



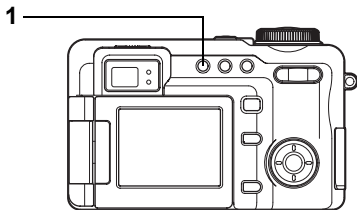

USER M Tv Av P PICT 3D

## Selecting the Flash Mode

### Flash Modes

(No icon)	Auto	The flash discharges automatically depending on the light conditions. You can select the Rear-curtain flash.
	Flash Off	The flash will not discharge, regardless of the brightness. Use this mode to take pictures at dusk or in locations where flash photography is prohibited (e.g., museums).
	Flash On	The flash discharges regardless of the brightness. You can select the Rear-curtain flash.
	Auto + Red-eye reduction	This mode reduces the phenomenon of red eyes caused by the light from the flash being reflected in the subject's eyes. The flash discharges automatically.
	Flash On + Red-eye reduction	This mode reduces the phenomenon of red eyes caused by the light from the flash being reflected in the subject's eyes. The flash will discharge regardless of the light conditions.
	R. Curtain	The flash is set to Rear-curtain flash. (Usually the flash discharges right after the shutter release button is pressed.) With Rear-curtain flash, the flash discharges right before the exposure ends. You can take pictures with different atmosphere when taking with a slow shutter speed. Rear-curtain flash can only be set when in Auto or  flash mode.



- The flash will not discharge (Flash Off) when in the mode, when is selected in PICT mode, when the drive mode is set to or or when the focus mode is set to or .
- A pre-flash discharges when using the red-eye reduction function.
- You cannot select Auto or in M mode.

# 1 Press the **⚡** button in Capture mode.

The flash mode changes each time the button is pressed and the icon appears on the LCD monitor.

The camera is ready to take pictures in the selected flash mode.

Saving the Flash Mode  p.107

## Selecting Rear-Curtain Flash

Rear-curtain flash can be set when the flash mode is set to Auto or the flash mode is set to **⚡** (Flash On). A normal front-curtain flash discharges right after the camera shutter opens, but a rear-curtain flash discharges right before the shutter closes. When using a rear-curtain flash with a slow shutter speed, you can capture a light trail from a moving subject.

### 1 Press the **Fn** button in the Auto or **⚡** mode.

The Fn guide screen appears.

### 2 Press the **⚡** button.

The Flash mode screen appears.

### 3 Use the four-way controller (**◀▶**) to select [F. Curtain (normal)] and [R. Curtain].

### 4 Press the **OK** button.

The camera is ready to take pictures.

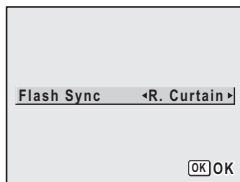

Rear-curtain flash cannot be set when the red-eye reduction function is activated.

Examples of pictures taken with a front-curtain flash and a rear-curtain flash are shown below.

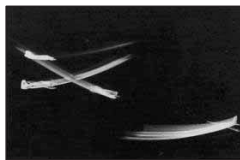

Front-curtain flash  
(normal)



Rear-curtain flash

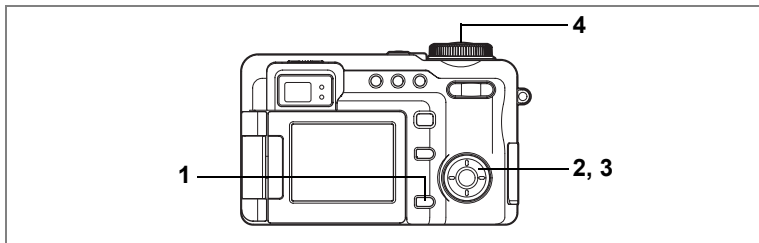

USER M Tv Av P PICT 3D 0

## Adjusting the Flash Intensity

You can adjust the amount of light emitted by the flash without having to change the brightness of the background.

### 1 Press the MENU button in Capture mode.

The [Rec. Mode] menu appears.

### 2 Use the four-way controller (▲▼) to select [Flash Exp. Comp.].

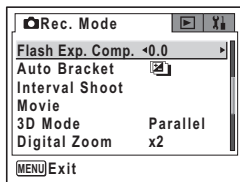

### 3 Use the four-way controller (◀▶) to change the light emission.

To increase the light emission, set a positive (+) value. To decrease the light emission, set a negative (-) value.

When pressing the shutter release button halfway in Capture mode, the flash icon appears as if a positive value has been set, and the flash icon appears as if a negative value has been set.

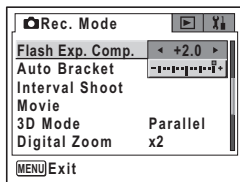

### 4 Press the shutter release button halfway.

The Flash Exp. Comp. setting is saved and the screen returns to capture status. Refer to Step 6 of “How to Use the Menu” (p.43) for other operations after the setting has been made.



- By combining flash exposure compensation with EV compensation, you can adjust the brightness of the background and the amount of light emitted by the flash separately.
- The flash intensity may not be compensated as set depending on the brightness and distance to the subject.
- Press the four-way controller (▲▼) in Step 3 above to set the exposure compensation and move between the menu pages.

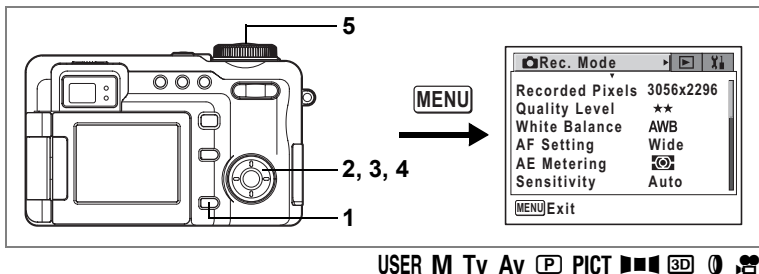

## Selecting the Recorded Pixels

You can select between 4:3 and 3:2 for the aspect ratio of still images. 4:3 is a normal aspect ratio of the images captured with a digital camera. When printing an image with no border and an aspect ratio of 4:3, part of the image may not appear on the print. Set the aspect ratio to 3:2 for prints with more of the original image.

You can also select from six recorded pixels settings for each aspect ratio.

The larger your recorded pixels, the finer the details will appear when you print your picture. The quality of the printed picture depends on the image quality, exposure control, resolution of the printer and other factors; therefore, you do not need select more than the required number of recorded pixels.

1024×768 is sufficient for printing a postcard-size print.

The more pixels there are, the larger the picture and the bigger the file size. The data volume also varies depending on the quality level setting (p.93).

### Recorded Pixels

Aspect Ratio of Image		Use
4:3	3:2	
3056×2296	3056×2040	↑ Fine Suitable for high-quality prints, large-sized prints and image processing  Suitable for postcard-size prints Suitable for use on websites or attaching to e-mails
2592×1944	2592×1728	
2048×1536	2048×1368	
1600×1200	1600×1064	
1024×768	1024×680	
640×480	640×424	

- 1 Press the **MENU** button in Capture mode.  
The [Rec. Mode] menu appears.
- 2 Use the four-way controller (▲▼) to select [Recorded Pixels].
- 3 Press the four-way controller (▶).  
A pull-down menu appears.
- 4 Use the four-way controller (▲▼) to change the number of recorded pixels.

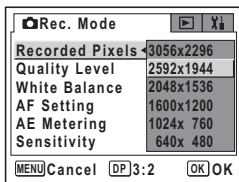

Press the **DPOF** button to switch between 4:3 and 3:2 for the aspect ratio of the image to be recorded. [3:2] appears after the recorded pixels when 3:2 is selected. When 3:2 is selected, the LCD monitor switches to a screen similar to that shown below on the right, enabling you to compose your picture accordingly.

4:3



3:2



- 5 Press the shutter release button halfway.

The Recorded Pixels setting is saved and the screen returns to capture status. Refer to Step 6 of “How to Use the Menu” (p.43) for other operations after the setting has been made.



The image in the viewfinder always appears with a 4:3 aspect ratio regardless of the aspect ratio setting of the image. Use the LCD monitor when taking pictures with the aspect ratio set to 3:2.

Recorded Pixels and Quality Level for Still Pictures  
p.20

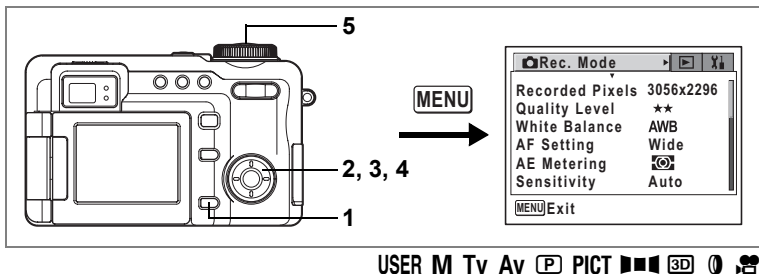

## Selecting the Quality Level

Image quality refers to the compression rate of still pictures. The more stars, the higher the quality and the larger the filesize. The recorded pixels setting also affects the filesize of your pictures (p.91).

### Quality Level

TIFF		Captures the image as uncompressed TIFF data. Suitable for editing images with the ACDSee software provided with the camera.
★★★	Best	Lowest compression rate. Suitable for photo prints. Images are saved as JPEG data.
★★	Better	Standard compression rate. Suitable for viewing the image on a computer screen. Images are saved as JPEG data.
★	Good	Highest compression rate. Suitable for attaching to e-mails or creating websites. Images are saved as JPEG data.

- 1 Press the MENU button in Capture mode.**  
The [Rec. Mode] menu appears.
- 2 Use the four-way controller (▲▼) to select [Quality Level].**
- 3 Press the four-way controller (▶).**  
A pull-down menu appears.
- 4 Use the four-way controller (▲▼) to change the quality level.**

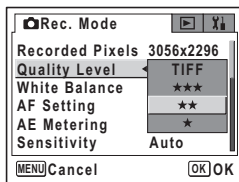

## 5 Press the shutter release button halfway.

The Quality Level setting is saved and the screen returns to capture status. Refer to Step 6 of “How to Use the Menus” (p.43) for other operations after the setting has been made.



- TIFF cannot be selected when the drive mode is set to or .
- TIFF can only be selected when the aspect ratio is set to 4:3 and the recorded pixels setting is 3056×2296 or 2592×1944.

Recorded Pixels and Quality Level for Still Pictures  
p.20



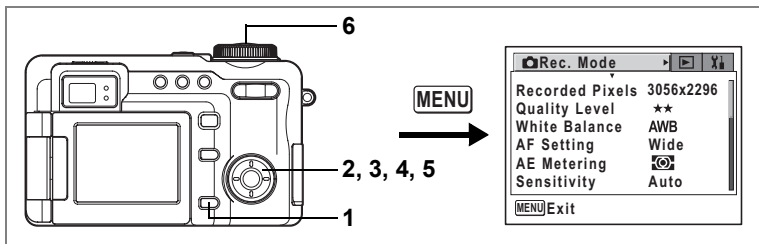

USER M Tv Av P ■■■ 3D 0

## Adjusting the White Balance

You can take pictures in natural colors by adjusting the white balance according to the light conditions at the time of shooting.

### White Balance Settings

<b>AWB</b>	Auto	The camera adjusts the white balance automatically.
	Daylight	Use this mode when taking pictures outside in sunlight.
	Shade	Use this mode when taking pictures outside in the shade.
	Tungsten Light	Use this mode when taking pictures under electric or other tungsten light.
	Fluorescent Light	Use this mode when taking pictures under fluorescent light. Choose the type of fluorescent light from W (white), D (daylight) and N (neutral).
	Manual	Use this mode when adjusting the white balance manually.

- 1 Press the MENU button in Capture mode.**  
The [Rec. Mode] menu appears.
- 2 Use the four-way controller (▲▼) to select [White Balance].**
- 3 Press the four-way controller (▶).**  
The White Balance screen appears.
- 4 Use the four-way controller (▲▼) to change the setting.**

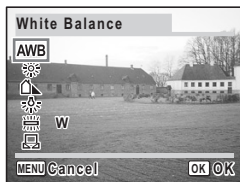

- 5** When the white balance is set to  (Fluorescent Light), use the four-way controller (◀▶) to select [W (white)], [D (daylight)] or [N (neutral)].

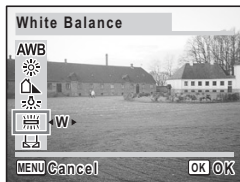

- 6** Press the shutter release button halfway.

The White Balance setting is saved and the screen returns to capture status. Refer to Step 6 of “How to Use the Menu” (p.43) for other operations after the setting has been made.

Saving the White Balance  p.107

Auto Bracketing  p.63

## Manual Setting

Have a blank sheet of white paper ready.

- 1** Select  (manual) on the White Balance screen.
- 2** Point the camera at the blank sheet of paper so that it fills the screen of the LCD monitor.
- 3** Press the shutter release button fully.

The white balance is automatically adjusted.

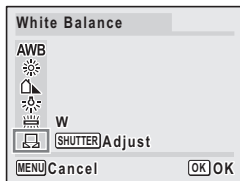

- 4** Press the **OK** button.

The setting is saved and the screen returns to the [📷 Rec. Mode] menu.

- 5** Press the **MENU** button.

The camera is ready to take pictures.



Any changes made to the White Balance setting are invalid in **PICT** mode.

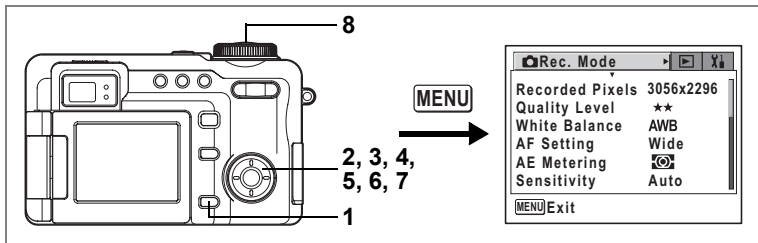

USER M Tv Av [P] PICT [ ] [3D] [ ]

## Setting the Autofocus Conditions

You can set various conditions for autofocus.

### Changing the Focusing Area

You can change the autofocus area (Focusing Area).

#### Focusing Area

Wide	Normal range
Spot	The autofocus range becomes smaller.



Spot autofocus is selected when the focus mode is set to . The focus is fixed when Capture mode is set to .

### Setting the Autofocus Mode

You can select the autofocus mode.

#### AF Mode

Single	The camera focuses on the subject when the shutter release button is pressed halfway. The focus locks when the subject is in focus.
Continuous	The camera continually focuses on the subject while displayed on the LCD monitor.

## Setting the Focus Limiter

You can limit the lens movement area according to conditions. Set the focus limiter to  to limit the focus to far distances during normal shooting and to close distances during macro shooting. This enables quicker focusing.

## Setting the Auxiliary AF Light

Set the Auxiliary AF Light to  for easier focusing by using the auxiliary AF light (redish orange) when the subject is dark and difficult to focus on.



The Auxiliary AF Light on this camera conforms to the safety standard (IEC60825-1) for a Class 1 LED product. Although looking directly at the Auxiliary AF Light poses no safety concerns, because the light is extremely bright, recommend you not to stare directly at the light at close range.

- 1 Press the MENU button in Capture mode.**  
The [Rec. Mode] menu appears.
- 2 Use the four-way controller (▲ ▼) to select [AF Setting].**
- 3 Press the four-way controller (▶).**  
The AF screen appears.
- 4 Use the four-way controller (▲ ▼) to select [Focusing Area].**
- 5 Press the four-way controller (▶).**  
A pull-down menu appears.
- 6 Use the four-way controller (▲ ▼) to change the setting.**

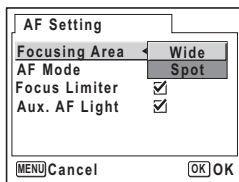
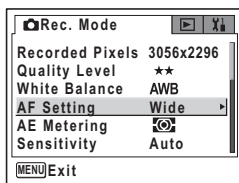

**7** Repeat Steps 4 to 6 to set [AF Mode], [Focus Limiter] and [Aux. AF Light].

**8** Press the shutter release button halfway.

The AF setting is saved and the screen returns to capture status. Refer to Step 6 of “How to Use the Menu” (p.43) for other operations after the setting has been made.

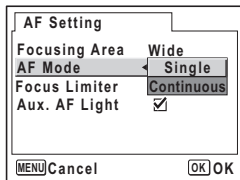

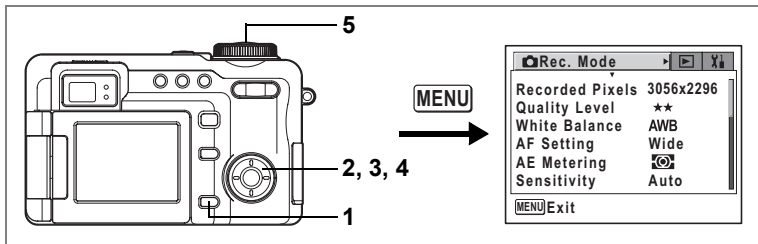

USER M Tv Av P PICT ■■■ 3D 0 0

## Setting the Light Metering Range to Determine the Exposure (AE Metering)

You can choose which part of the screen to use to measure the brightness and determine the exposure.

### AE Metering Modes

	Multi-segment	The exposure is determined by the entire screen.
	Center-weighted	The exposure is determined mainly by the center of the screen.
	Spot	The exposure is determined by the small area in the center of the screen only.

- 1 Press the MENU button in Capture mode.**  
The [Rec. Mode] menu appears.
- 2 Use the four-way controller (▲▼) to select [AE Metering].**
- 3 Press the four-way controller (▶).**  
A pull-down menu appears.
- 4 Use the four-way controller (▲▼) to change the AE Metering mode.**
- 5 Press the shutter release button halfway.**

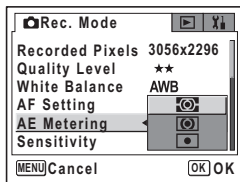

The AE Metering setting is saved and the screen returns to capture status. Refer to Step 6 of “How to Use the Menu” (p.43) for other operations after the setting has been made.

Saving the AE Metering Mode ■■■ p.107

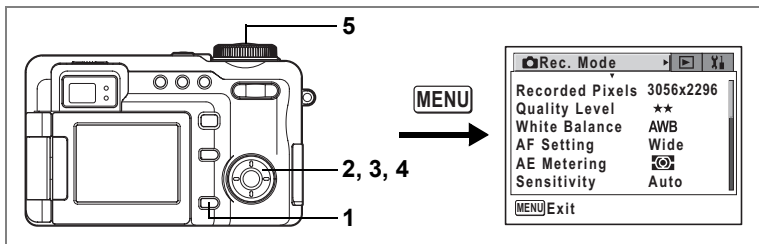

USER M Tv Av P PICT ■■■ 3D 0

## Setting the Sensitivity

You can select the sensitivity to suit the brightness of the surroundings.

### Sensitivity

Auto	The camera sets the sensitivity automatically.
80	<ul style="list-style-type: none"> <li>The lower the sensitivity, the sharper the image and the less noise. The shutter speed will be slower in low light conditions.</li> <li>The higher the sensitivity, the faster the shutter speed in low light conditions to reduce camera shake, but the image may be affected by noise.</li> </ul>
100	
200	
400	

- Press the **MENU** button in Capture mode.  
The [Rec. Mode] menu appears.
- Use the four-way controller (▲▼) to select [Sensitivity].
- Press the four-way controller (▶).  
A pull-down menu appears.
- Use the four-way controller (▲▼) to change the sensitivity.
- Press the shutter release button halfway.

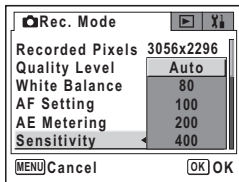

The Sensitivity setting is saved and the screen returns to capture status. Refer to Step 6 of “How to Use the Menus” (p.43) for other operations after the setting has been made.



The Sensitivity setting on the [Rec. Mode] menu does not affect the settings in Digital Exposure Metering mode. Use the [Digital Exp. Metering] menu to set the sensitivity for Digital Exposure Metering mode (p.169).

Saving the Sensitivity p.107

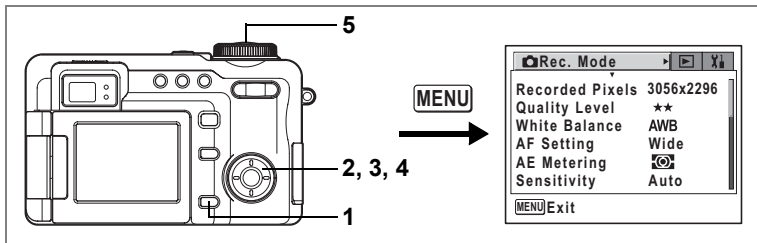

USER M Tv Av [P] PICT [ ] [3D] [ ]

## Setting the Instant Review Time (Instant Review)

You can choose the Instant Review time from 0.5 sec, 1 sec, 2 sec, 3 sec, 4 sec, 5 sec and Off (no display).

4

- 1 Press the MENU button in Capture mode.**  
The [Rec. Mode] menu appears.
- 2 Use the four-way controller (▲▼) to select [Instant Review].**
- 3 Press the four-way controller (▶).**  
A pull-down menu appears.
- 4 Use the four-way controller (▲▼) to change the display time.**
- 5 Press the shutter release button halfway.**

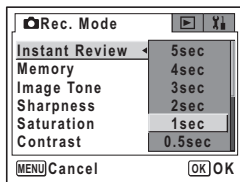

The Instant Review setting is saved and the screen returns to capture status. Refer to Step 6 of “How to Use the Menus” (p.43) for other operations after the setting has been made.

Instant Review p.34



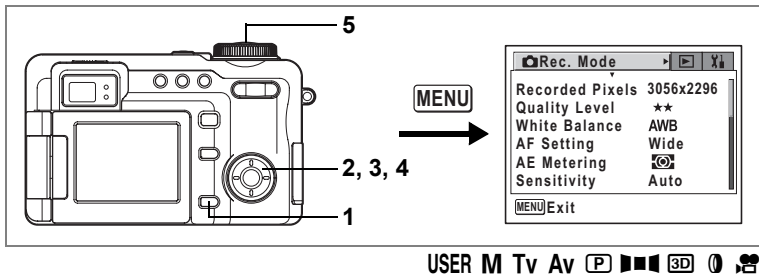

## Selecting the Image Tone

The basic image tone can be adjusted as desired.

### Image Tone

Standard	Creates a picture with standard image tone.
Vivid	Creates a picture with vivid image tone.

- 1 Press the MENU button in Capture mode.**  
The [Rec. Mode] menu appears.
- 2 Use the four-way controller (▲▼) to select [Image Tone].**
- 3 Press the four-way controller (▶).**  
A pull-down menu appears.
- 4 Use the four-way controller (▲▼) to choose the image tone.**
- 5 Press the shutter release button halfway.**

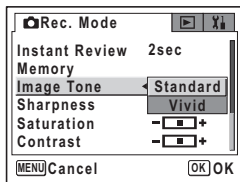

The Image Tone setting is saved and the screen returns to capture status. Refer to Step 6 of “How to Use the Menus” (p.43) for other operations after the setting has been made.

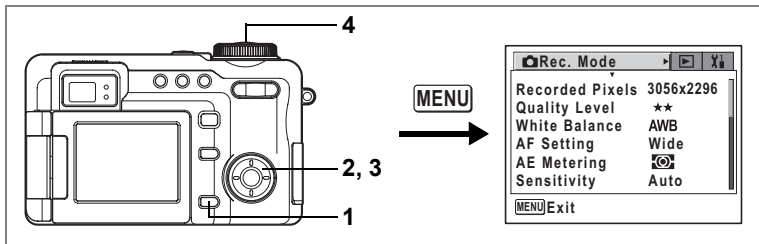

USER M Tv Av [P] [ ] [3D] [ ] [ ]

## Setting the Image Sharpness (Sharpness)

You can choose whether you want the image to have sharp or soft outlines.

- 1 Press the MENU button in Capture mode.**  
The [Rec. Mode] menu appears.
- 2 Use the four-way controller (▲▼) to select [Sharpness].**
- 3 Use the four-way controller (◀▶) to change the setting from [Standard] to [Hard (+)] or [Soft (-)].**
- 4 Press the shutter release button halfway.**

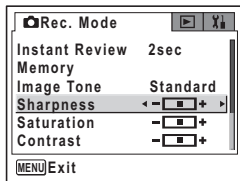

To soften the contours, choose (-) and to sharpen the contours, choose (+).

The Sharpness setting is saved and the screen returns to capture status. Refer to Step 6 of "How to Use the Menu" (p.43) for other operations after the setting has been made.



Any changes made to the Sharpness setting are invalid in PICT mode.

Auto Bracketing [ ] p.63

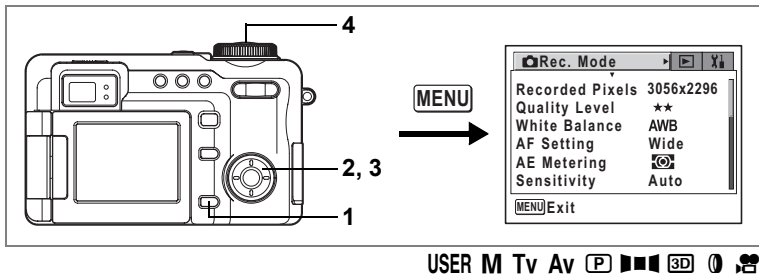

## Setting the Color Saturation (Saturation)

You can set the color saturation.

- 1 Press the MENU button in Capture mode.**  
The [Rec. Mode] menu appears.
- 2 Use the four-way controller (▲▼) to select [Saturation].**
- 3 Use the four-way controller (◀▶) to change the setting from [Standard] to [High (+)] or [Low (-)].**  
To reduce the saturation, choose (-) and to increase the saturation, choose (+).
- 4 Press the shutter release button halfway.**

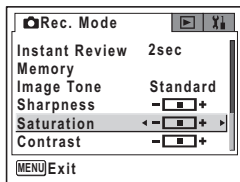

Any changes made to the Saturation setting are invalid in PICT mode.

Auto Bracketing p.63

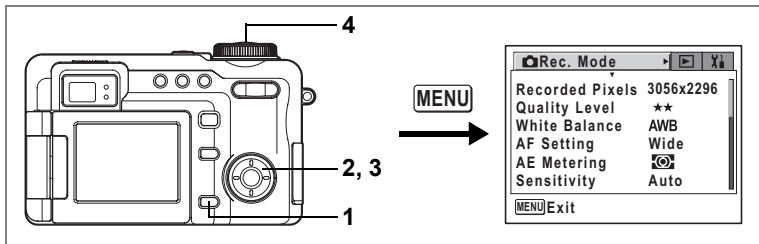

USER M Tv Av P

## Setting the Image Contrast (Contrast)

You can set the image contrast.

4

### 1 Press the MENU button in Capture mode.

The [Rec. Mode] menu appears.

### 2 Use the four-way controller (▲▼) to select [Contrast].

### 3 Use the four-way controller (◀▶) to change the setting from [Standard] to [High (+)] or [Low (-)].

To reduce the contrast, choose (-) and to increase the contrast, choose (+).

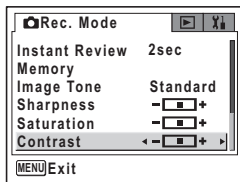

### 4 Press the shutter release button halfway.

The Contrast setting is saved and the screen returns to capture status. Refer to Step 6 of “How to Use the Menu” (p.43) for other operations after the setting has been made.



Any changes made to the Contrast setting are invalid in PICT mode.

Auto Bracketing p.63

# Saving the Settings (Memory)

You can choose whether you want the set values to be saved when the camera is turned off or returned to the defaults. The items that can be saved or reset are listed below. If you select  (On), the settings will be saved in the status they were in immediately before the camera was turned off. If you select  (Off), the settings will be reset to the defaults when the camera is turned off. Items not listed here will also be saved in the selected settings when the camera is turned off.

Item	Description	Default Setting
Flash	The flash mode set with the  button (p.87)	<input checked="" type="checkbox"/>
Flash Exp. Comp.	The [Flash Exp. Comp.] setting on the [ Rec. Mode] menu (p.89)	<input type="checkbox"/>
White Balance	The [White Balance] setting on the [ Rec. Mode] menu (p.95)	<input type="checkbox"/>
EV Compensation	The EV compensation value set with the front lever (p.59)	<input type="checkbox"/>
Digital Zoom	The [Digital Zoom] setting on the [ Rec. Mode] menu (p.58)	<input checked="" type="checkbox"/>
AE Metering	The [AE Metering] setting on the [ Rec. Mode] menu (p.100)	<input type="checkbox"/>
Sensitivity	The [Sensitivity] setting on the [ Rec. Mode] menu (p.101)	<input type="checkbox"/>
Focus Mode	The focus mode set with the  button (p.84)	<input type="checkbox"/>
Zoom Position	The optical zoom position set with the Zoom button (p.57)	<input type="checkbox"/>
MF Position	The manual focus position set with the  button (p.85)	<input type="checkbox"/>
DISPLAY	The LCD monitor display mode (p.81, 121)	<input type="checkbox"/>
File #	The file number is saved. If a new SD Memory Card is inserted when On has been selected, file numbers are assigned sequentially.	<input checked="" type="checkbox"/>
Drive Mode	The drive mode set with the  button (pp.60 - 73)	<input type="checkbox"/>



The zoom position setting in the digital zoom range will not be saved even if [Zoom Position] is set to On in [Memory].

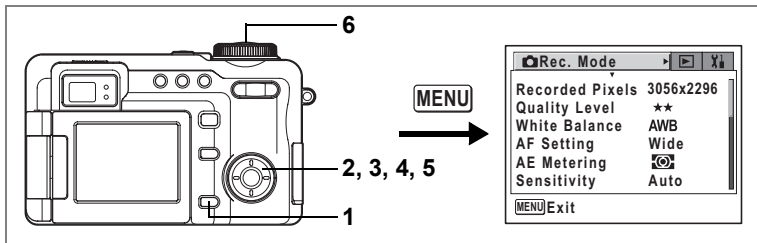

## Memory

<input checked="" type="checkbox"/>	The settings will be saved in the status they were in immediately before the camera was turned off.
<input type="checkbox"/>	The settings will be reset to the defaults when the camera is turned off.

4

Taking Pictures

- 1 Press the MENU button in Capture mode.**  
The [📷 Rec. Mode] menu appears.
- 2 Press the four-way controller (▲▼) to select [Memory].**
- 3 Press the four-way controller (▶).**  
The Memory screen appears.
- 4 Use the four-way controller (▲▼) to choose an item.**
- 5 Use the four-way controller (◀▶) to select  (On) or  (Off).**
- 6 Press the shutter release button halfway.**

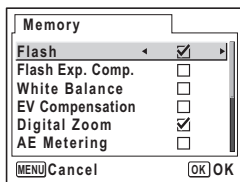

The Memory setting is saved and the screen returns to capture status. Refer to Step 6 of “How to Use the Menus” (p.43) for other operations after the setting has been made.

# Taking Movies

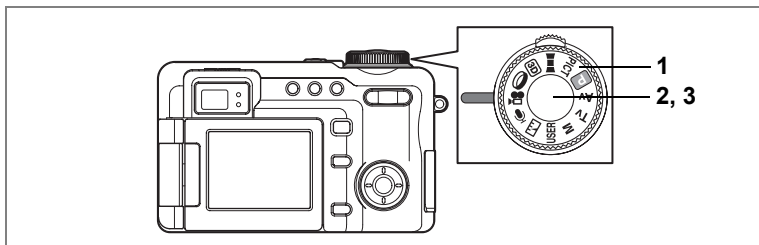



## Recording Movies



This mode lets you take movies. Sound is recorded at the same time.

### 1 Set the mode dial to .

Before starting recording, you can change the captured area using the optical zoom.

Press the Zoom// button to the right or left to change the area.

 : enlarges the subject

 : enlarges the area captured by the camera

### 2 Press the shutter release button fully.

Recording starts.



The following information appears on the LCD monitor.

1 Movie mode icon

2 Recording indicator (blinks during recording)

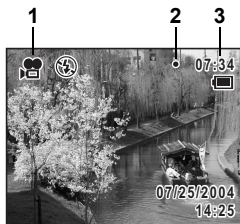
3 Remaining recording time



When the image quality is set to 320×240, press the Zoom// button to the right or left to change the captured area using the digital zoom.

When the image quality is set to 640×480, the digital and optical zooms cannot be used after starting recording. Set the desired zoom magnification before starting recording.

### 3 Press the shutter release button fully.

Recording stops.



- The flash will not discharge in Movie mode.
- The focus status lamp on the right of the viewfinder blinks during recording.

Playing Back Movies  p.125

#### Keeping the Shutter Release Button Pressed

Recording starts when you keep the shutter release button pressed for more than one second. Recording will continue for as long as you keep the button pressed. Recording stops when you take your finger off the shutter release button.



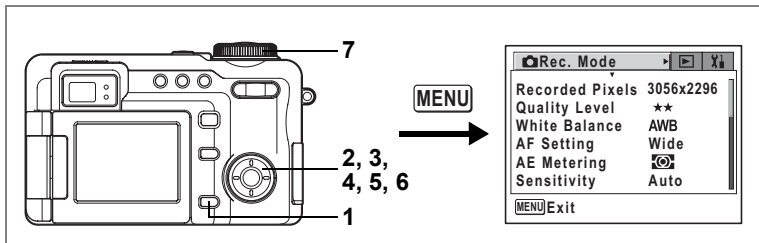

## Selecting the Recorded Pixels for Movies

You can choose the number of recorded pixels for movies from [640×480] and [320×240].

The more pixels there are, the larger the picture and the bigger the file size. The data volume also varies depending on the quality level setting (ⓘ p.22).

### Recorded Pixels for Movies

640×480	Produces high quality movies at VGA size, but with a shorter recording time.
320×240	Produces smaller images, but with a longer recording time.

- 1 Press the MENU button in Capture mode.**  
The [📷 Rec. Mode] menu appears.
- 2 Use the four-way controller (▲▼) to select [Movie].**
- 3 Press the four-way controller (▶).**  
The Movie screen appears.
- 4 Use the four-way controller (▲▼) to select [Recorded Pixels].**
- 5 Press the four-way controller (▶).**  
A pull-down menu appears.
- 6 Use the four-way controller (▲▼) to change the number of recorded pixels.**
- 7 Set the mode dial to 📷.**

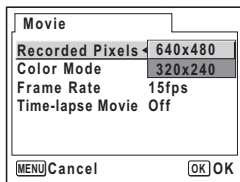

The Recorded Pixels setting is saved and the camera is ready to record.

Recorded Pixels and Quality Level for Movies ⓘ p.22

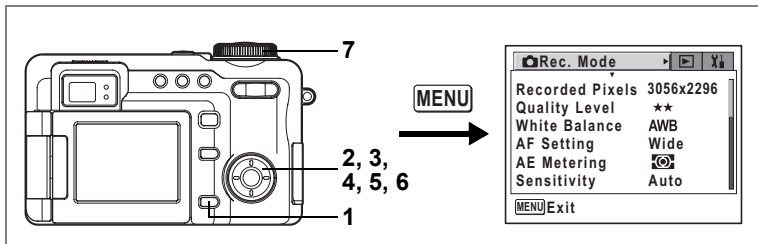

## Adding a Color Effect to Movies (Color Mode)

You can add a color effect to movies by using color filters. As well as recording in normal colors, you can choose a B&W filter or a Sepia filter.

4

Taking Pictures

### 1 Press the MENU button in Capture mode.

The [Rec. Mode] menu appears.

### 2 Use the four-way controller (▲▼) to select [Movie].

### 3 Press the four-way controller (▶).

The Movie screen appears.

### 4 Use the four-way controller (▲▼) to select [Color Mode].

### 5 Press the four-way controller (▶).

A pull-down menu appears.

### 6 Use the four-way controller (▲▼) to choose a color.

### 7 Set the mode dial to .

The selected color mode is enabled and the camera is ready to record.

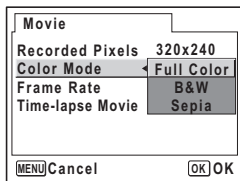

Digital filters are available for use with still pictures. (p.74)

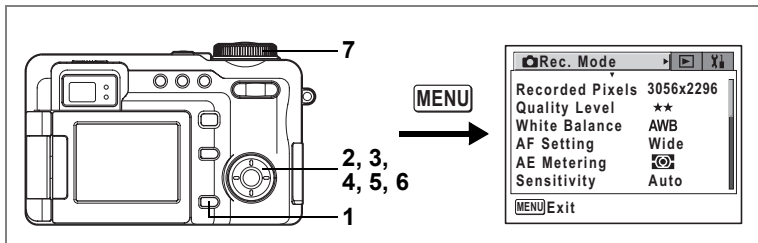

## Selecting the Frame Rate

The frame rate refers to the number of frames taken per second. The higher the frame rate, the smoother the movie and the larger the filesize. There are two frame rates to choose from: 30fps (frames/sec.) and 15fps.

- 1 Press the MENU button in Capture mode.**  
The [📷 Rec. Mode] menu appears.
- 2 Use the four-way controller (▲▼) to select [Movie].**
- 3 Press the four-way controller (▶).**  
The Movie screen appears.
- 4 Use the four-way controller (▲▼) to select [Frame Rate].**
- 5 Press the four-way controller (▶).**  
A pull-down menu appears.
- 6 Use the four-way controller (▲▼) to select [30fps] or [15fps].**
- 7 Set the mode dial to 📷.**  
The Frame Rate setting is saved and the camera is ready to record.

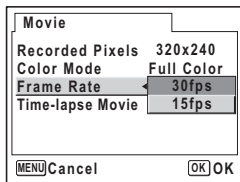

Recorded Pixels and Quality Level for Movies ▶▶▶ p.22

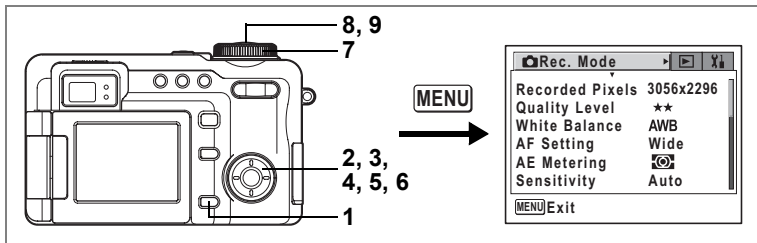

## Taking Time-lapse Movies

This mode lets you take movies at a delayed frame rate so that when you play the movie back at the normal frame rate, the action appears speeded up. For example, if you choose the  $\times 2$  setting, half the normal number of frames will be taken, so that when you play the movie back at the normal frame rate, it will be played back at twice the normal speed.

- 1 Press the MENU button in Capture mode.**  
The [Rec. Mode] menu appears.
- 2 Use the four-way controller ( $\blacktriangle \blacktriangledown$ ) to select [Movie].**
- 3 Press the four-way controller ( $\blacktriangleright$ ).**  
The Movie screen appears.
- 4 Use the four-way controller ( $\blacktriangle \blacktriangledown$ ) to select [Time-lapse Movie].**
- 5 Press the four-way controller ( $\blacktriangleright$ ).**  
A pull-down menu appears.
- 6 Use the four-way controller ( $\blacktriangle \blacktriangledown$ ) to change the time-lapse setting.**
- 7 Set the mode dial to .**  
The camera is ready to record a time-lapse movie.

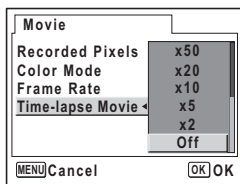

## 8 Press the shutter release button fully.

The camera starts recording a time-lapse movie.

The selected time-lapse setting appears on the LCD monitor.



## 9 Press the shutter release button fully.

Recording stops.



The time-lapse movie is recorded at 15 fps without sound regardless of the Frame Rate setting (p.113).

## Playing Back Still Pictures

### Switching between Capture Mode and Playback Mode

Capture mode is for taking and recording images. Playback mode is for viewing captured pictures. The displayed picture can be edited in Playback mode.

Follow the procedure below to switch between Capture mode and Playback mode.

#### To Change from Capture Mode to Playback Mode

- 1 Press the  button.**

The camera switches to Playback mode.

#### To Change from Playback Mode to Capture Mode

- 1 Press the  button or the shutter release button halfway or fully.**

The camera switches to Capture mode.

### Playing Back Still Pictures

Refer to “Playing Back Images” (p.35) for instructions.

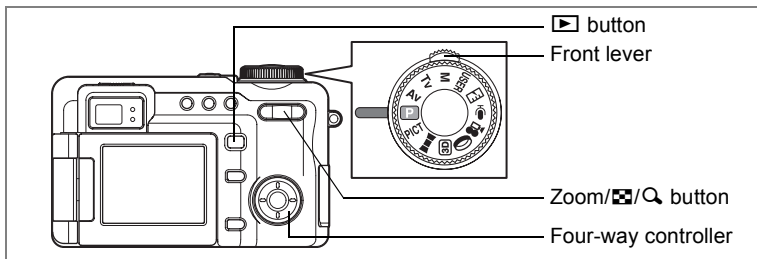

## Nine-Image Display and Folder Display

You can display thumbnails of nine captured images at a time.

### 1 Press on the Zoom/Still/Quick button in Playback mode.

Nine images appear with the selected image at the bottom center.

Use the four-way controller (, , , ) to move the frame. If you choose image ① and press the front lever or the four-way controller () when ten or more images have been recorded, the previous nine images appear. Similarly, if you choose image ② and press the four-way controller (), the next nine images appear.

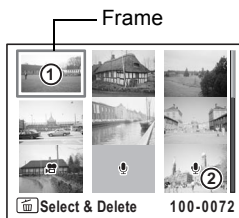

The icons that appear on the images indicate the following:





- No icon : Still picture without voice memo
- (with image) : Still picture with voice memo
- : Movie (first frame appears)
- (without image) : Sound file only

Press the Zoom/Still/Quick button toward or press the **OK** button to switch to the full screen display of the selected image.



Press the button to switch to Capture mode.

**2** Press  on the Zoom//Quit button.

The list of folders appears.

**3** Use the four-way controller () to choose a folder.

Press the Zoom//Quit button toward Quit, or press the **OK** or  button, to display the folder images in nine-image display.

Next, press the Zoom//Quit button toward Quit, or press the **OK** or  button, to switch to the full screen display of the selected image.

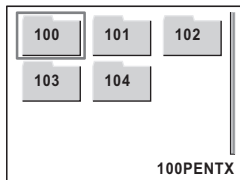



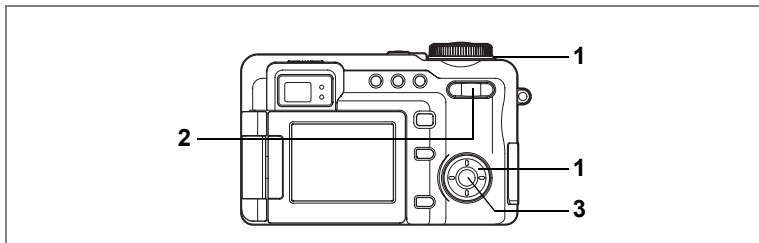

## Zoom Display

You can display images magnified up to ten times. A guide to operation appears on the LCD monitor during magnification.

**1 Enter the Playback mode and use the front lever or four-way controller (◀▶) to choose an image to magnify.**

**2 Press the Zoom/⏏/Q button toward Q.**

The image is magnified (1× to 10×). Holding down the button changes the magnification continuously.



**The following operations can be performed while the magnified image is displayed.**

- Four-way controller (▲▼◀▶) Moves the position to be magnified
- Zoom/⏏/Q button (Q) Makes the image bigger
- Zoom/⏏/Q button (⏏) Makes the image smaller

**3 Press the OK button.**

Zoom playback ends.



Movies cannot be magnified.

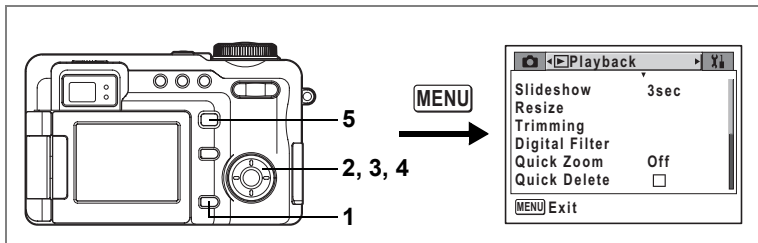

## Setting the Quick Zoom Function

You can display the image at the set magnification simply by pressing the Zoom//Q button toward Q once during zoom playback.

### 1 Press the MENU button in Playback mode.

The [▶ Playback] menu appears.

### 2 Use the four-way controller (▲▼) to select [Quick Zoom].

### 3 Press the four-way controller (▶).

A pull-down menu appears.

### 4 Use the four-way controller (▲▼) to change the magnification.

×2, ×4, ×10 : Pressing the Zoom//Q button once toward Q takes the image straight to the selected magnification and after that magnifies the image in steps.

Off : Pressing the Zoom//Q button toward Q once magnifies the image in steps in the range of ×1.1 to ×10.0.

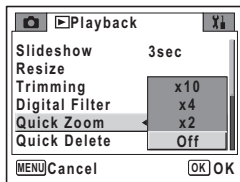

### 5 Press the ▶ button.

The camera is ready to play back images.

Refer to Step 6 of “How to Use the Menus” (p.43) for other operations after the setting has been made.

## Displaying Shooting Information in Playback Mode

Shooting information can be displayed on the LCD monitor in Playback mode. Pressing the **OK** button changes the display mode.

**Normal Display** : Displays the shooting information.

**Histogram Display** : Displays the brightness distribution of the image. The horizontal axis shows the brightness (darkest at the left end and brightest at the right end) and the vertical axis shows the number of pixels. Bright portions on the screen blink red and dark portions blink yellow.

### Normal Display

- 1 Fn button indicator (p.148)
- 2 Digital zoom display (p.119)
- 3 Voice memo icon (p.149)
- 4 Folder number
- 5 File number
- 6 Protect icon (p.131)
- 7 Battery level indicator (p.16)
- 8 Date and time (p.29)
- 9 Four-way controller icon
- 10 Aperture (p.50)
- 11 Shutter speed (p.51)

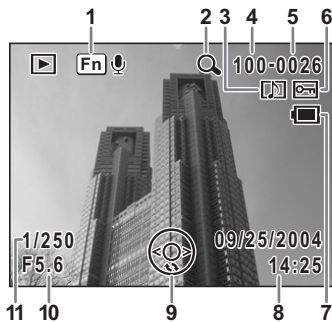

### Histogram Display

- 1 White balance (p.95)
- 2 Recorded pixels (p.91)
- 3 Quality level (p.93)
- 4 Bright portions
- 5 Histogram
- 6 Dark portions
- 7 Sensitivity (p.101)
- 8 AE metering (p.100)

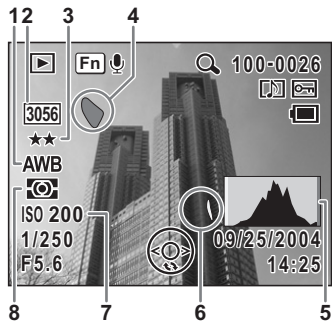

## No icons

No shooting information is displayed.



No icons



Normal display

Displaying Shooting Information in Capture Mode  
p.81

## About the Bright and Dark Portions

When the histogram is displayed, the bright portions in the picture blink red and the dark portions blink yellow. This indicates that the portions are too bright or too dark and details will not appear when the image is viewed on a PC or printed.

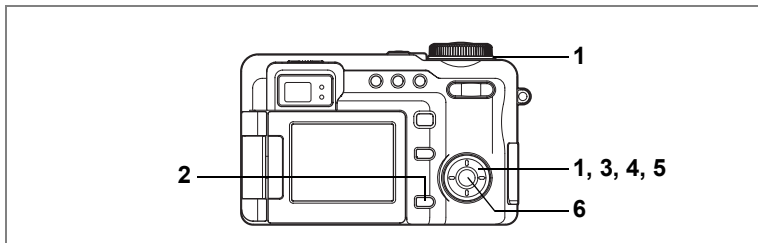

## Slideshow

You can play back all the images on the SD Memory Card one after another.

**1 Enter the Playback mode and use the front lever or four-way controller (◀▶) to choose the image with which to start the slideshow.**

**2 Press the MENU button.**

The [▶] Playback] menu appears.

**3 Use the four-way controller (▲▼) to select [Slideshow].**

To start the slideshow with the current settings, go to Step 6 below.

**4 Press the four-way controller (▶).**

A pull-down menu appears.

**5 Use the four-way controller (▲▼) to change the playback interval.**

Choose from the following: 3 sec, 5 sec, 10 sec, 15 sec, 20 sec, 30 sec

**6 Press the OK button.**

The slideshow starts at the set interval.

Press any button, such as the **OK** button or **MENU** button, to stop the slideshow.

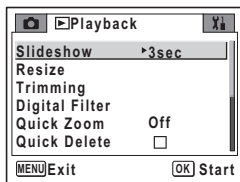



- The slideshow will continue until you press any button.
- Images that take time to display, such as TIFF images, are displayed for two seconds before the next image is displayed.
- Pictures with a voice memo will be played through to the end before the next picture is played back, regardless of the set playback interval.
- Pressing the four-way controller (▶) while playing back a movie displays the next image.
- Sound files made in Voice Recording mode are not played back.

Viewing Still Pictures and Movies on a TV p.126

# Playing Back Movies

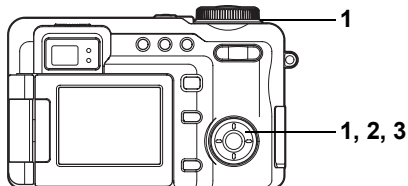

## Playing Back Movies

You can play back the movies you have taken. A guide to operation appears on the LCD monitor during playback. Sound is played back at the same time.

**1 Enter the Playback mode and use the front lever or four-way controller (◀▶) to choose an image to play back.**

**2 Press the four-way controller (▲).**

Playback starts.



**The following operations can be performed during playback.**

- Four-way controller (◀) Reverse playback
- Four-way controller (▶) Forward playback
- Four-way controller (▲) Pause
- Zoom/⊞/Q button (↑) Increases the volume
- Zoom/⊞/Q button (⏏) Reduces the volume

**The following operations can be performed while Pause is engaged.**

- Four-way controller (◀) Frame reverse (fast reverse 15 frames at a time)
- Four-way controller (▶) Frame forward
- Four-way controller (▲) Releases the Pause function (Play)

**3 Press the four-way controller (▼).**

Playback stops and the screen returns to the start screen.

# Viewing Still Pictures and Movies on a TV

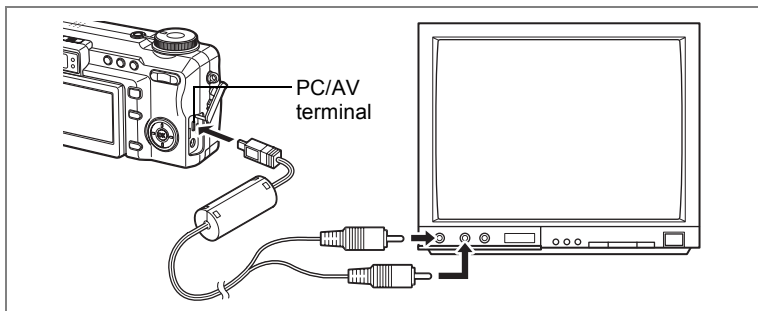

By using the AV cable, you can capture and play back images on a TV or other equipment with a video IN jack. Make sure that both the TV and the camera are turned off before connecting the cable.

5

Playing Back and Deleting Images

**1 Open the terminal cover and connect the AV cable to the PC/AV terminal.**

**2 Connect the other ends of the AV cable to the image input terminal and sound input terminal on the TV.**

When using stereo sound equipment, insert the sound terminal into the L (white) terminal.

**3 Turn the TV and camera on.**



- If you intend to use the camera for a long time, use of the AC adapter D-AC7 (optional) is recommended.
- The video output format varies depending on the country or region. If you have any problems displaying the images, check the video output format. Refer to the operating manual for the TV or equipment to which the camera is connected.

Changing the Video Output Format p. 160



# Deleting

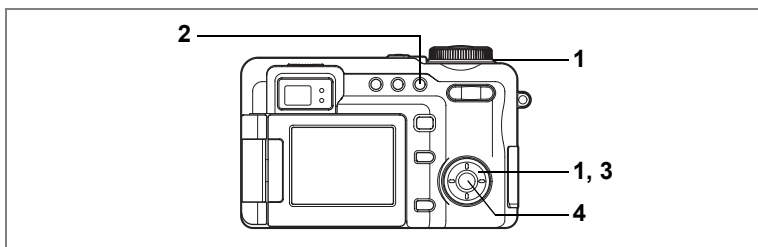

## Deleting Single Images and Sound Files

You can delete single images and sound files one at a time.



- Once deleted, images cannot be restored.
- You cannot delete protected images. (p.131)

- 1 Enter the Playback mode and use the front lever or four-way controller (◀▶) to choose an image or sound file to delete.**
- 2 Press the  button.**  
The Delete screen appears.
- 3 Use the four-way controller (▲) to select [Delete].**
- 4 Press the OK button.**  
The image or sound file is deleted.



If [Quick Delete] is set to  (On) in the [▶ Playback] menu, you can skip Step 3. (p.128)

## Deleting Voice Memos Only

If an image has a voice memo, you can delete the voice memo without deleting the image.

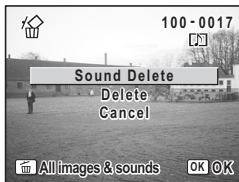

- 1 Enter the Playback mode and use the four-way controller (◀▶) to choose an image with a voice memo to delete.**
- 2 Press the  button.**  
The Delete screen appears.
- 3 Use the four-way controller (▲▼) to select [Sound Delete].**
- 4 Press the OK button.**  
The voice memo is deleted.



Select [Delete] in Step 3 above to delete both the image and the voice memo.

## Setting the Quick Delete Function

When the Quick Delete function is set to  (On), the Delete screen appears with [Delete] already highlighted.

- 1 Press the MENU button in Playback mode.**  
The [ Playback] menu appears.
- 2 Use the four-way controller (▲▼) to select [Quick Delete].**
- 3 Use the four-way controller (◀▶) to select  (On) or  (Off).**
- 4 Press the  button.**  
The camera is ready to play back images.  
Refer to Step 6 of “How to Use the Menu” (p.43) for other operations after the setting has been made.

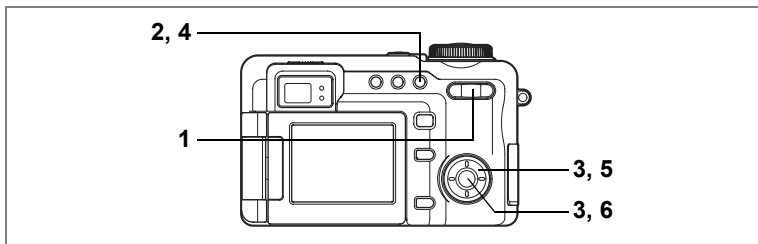

## Deleting Selected Images and Sound Files (from Nine-Image Display)

You can delete images and sound files from nine-image display at once.



- Once deleted, images cannot be restored.
- Protected images and sound files cannot be deleted.

**1 Press the Zoom//Q button toward in Playback mode.**

Nine images appear with the selected image at the bottom center.

**2 Press the button.**

**3 Use the four-way controller (, , , ) to choose the images and sound files to delete and press the OK button.**

appears on the selected images.

You can also press and hold the Zoom//Q button toward to display a full screen display of the selected image. Once you release the button, the screen returns to the nine-image display. You

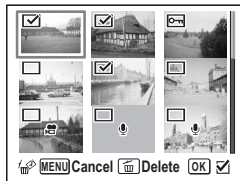

cannot gain full screen display of protected images.

**4 Press the button.**

The Delete Confirmation screen appears.

**5 Use the four-way controller (, ) to select [Select & Delete].**

**6 Press the OK button.**

The selected images and sound files are deleted.



You can select up to 9999 images at once.

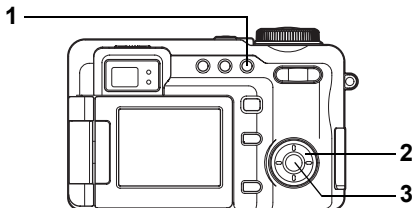

## Deleting All Images

You can delete all the images and sound files at once.



- Once deleted, images cannot be restored.
- Protected images and sound files cannot be deleted.

5

### 1 Press the button twice in Playback mode.

The Delete All screen appears.

### 2 Use the four-way controller () to select [Delete All].

### 3 Press the OK button.

All the images and sound files are deleted.



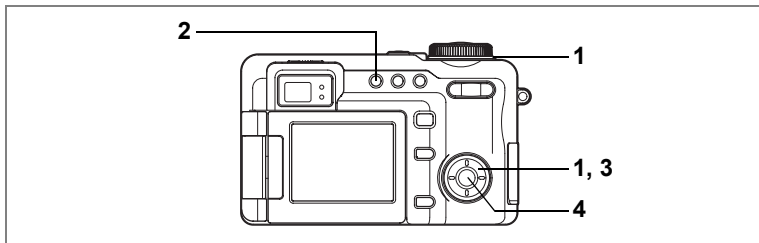

## Protecting Images and Sound Files from Deletion (Protect)

You can protect images and sound files from being accidentally deleted.

- 1 Enter the Playback mode and use the front lever or four-way controller (◀▶) to choose an image or sound file to protect.**
- 2 Press the  button.**  
The Protect screen appears.
- 3 Use the four-way controller (▲) to select [Protect].**
- 4 Press the OK button.**  
The selected image is protected.



- To cancel the Protect setting, select [Unprotect] in Step 3.
-  appears on protected images or sound files during playback.

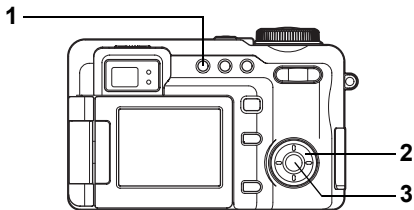

## Protecting All Images and Sound Files

You can protect all your images and sound files.



Protected images and sound files will be deleted when the SD Memory Card is formatted.

### 1 Press the button twice in Playback mode.

The Protect All screen appears.

### 2 Use the four-way controller () to select [Protect].

### 3 Press the OK button.

All the images and sound files are protected.



To cancel the Protect setting on all your images and sound files, select [Unprotect] in Step 2.

## Editing Still Pictures

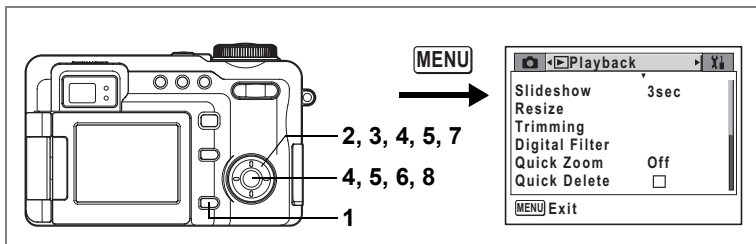

## Changing the Image Size and Quality (Resize)

By changing the size and quality of a selected image, you can make the file smaller than the original. You can use this function to continue taking pictures when the SD Memory Card is full, by making the images smaller and overwriting the original images to make more space available in the memory.

- 1 Press the MENU button in Playback mode.**  
The [▶ Playback] menu appears.
- 2 Use the four-way controller (▲▼) to select [Resize].**
- 3 Press the four-way controller (▶).**  
The Resize screen appears.
- 4 Use the four-way controller (◀▶) to choose the image to resize and press the OK button.**  
The screen for selecting the resolution and quality appears.

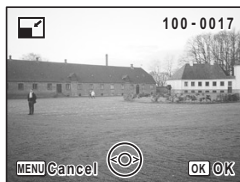

- 5 Select the resolution and quality.**  
Press the four-way controller (▶) to display the pull-down menu and use the four-way controller (▲▼) to select the resolution and quality, then press the OK button.  
You cannot select a larger resolution or higher quality than that of the original image.

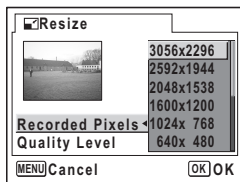

## 6 Press the **OK** button.

The overwrite confirmation screen appears.

## 7 Use the four-way controller (▲▼) to select **[Overwrite]** or **[Save as]**.

## 8 Press the **OK** button.

The resized image is saved.

Press the shutter release button or the

 button to cancel image resizing and return to Capture mode or Playback mode.

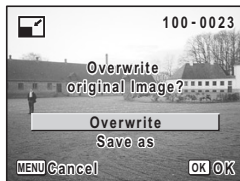

- TIFF images cannot be resized.
- Movies cannot be resized.
- You cannot select greater recorded pixels or a higher quality than that of the original image.



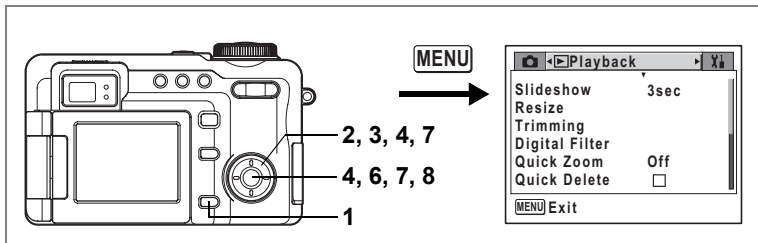

## Trimming Images

You can delete the unneeded part of a picture and save the trimmed image as a separate image.

- 1 Press the MENU button in Playback mode.**  
The [▶ Playback] menu appears.
- 2 Use the four-way controller (▲▼) to select [Trimming].**
- 3 Press the four-way controller (▶).**  
Images that can be trimmed appear.
- 4 Use the four-way controller (◀▶) to choose the image to trim and press the OK button.**  
The Trimming screen appears.
- 5 Choose the trimming conditions.**

**Operations that can be performed on the Trimming screen**

Four-way controller (▲▼◀▶)

Moves the trimming position up, down, left and right

Zoom/📐/Q button

Changes the size of the trimmed section

🔄 button

Rotates the trimming area

**DPOF** button

Changes the aspect ratio of the trimming area (4:3 ↔ 3:2)

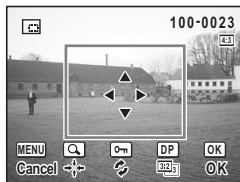

## 6 Press the OK button.

The screen for selecting the resolution and quality appears.

## 7 Select the resolution and quality.

Press the four-way controller (▶) to display the pull-down menu and use the four-way controller (▲▼) to select the resolution and quality, then press the **OK** button.

You cannot select a larger resolution or higher quality than that of the original image.

## 8 Press the OK button.

The trimmed image is saved with a new name.

Press the shutter release button or the  button to cancel image trimming and return to Capture mode or Playback mode.

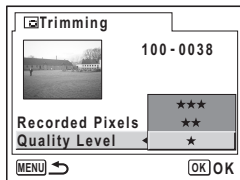

- TIFF images cannot be trimmed.
- Movies cannot be trimmed.
- The image is saved according to the trimming size.

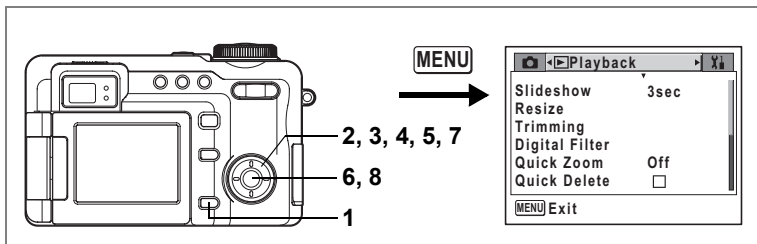

## Editing Pictures with Digital Filters

This function enables you to edit still pictures with digital filters. You can choose from ten color filters: B&W, Sepia, Red, Pink, Purple, Blue, Green, Yellow, Soft and Brightness.

### 1 Press the **MENU** button in Playback mode.

The [▶] Playback menu appears.

### 2 Use the four-way controller (▲▼) to select [Digital Filter].

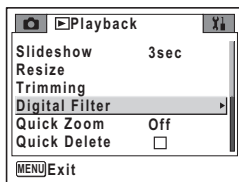

### 3 Press the four-way controller (▶).

Images that can be edited with the digital filters appear.

### 4 Use the four-way controller (◀▶) to choose an image.

### 5 Use the four-way controller (▲▼) to choose a digital filter.

When selecting B&W, press the front lever to the right or left to adjust the brightness.

### 6 Press the **OK** button.

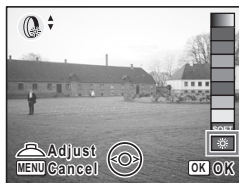

**7** Use the four-way controller (▲▼) to select [Overwrite] or [Save as].

**8** Press the OK button.

The image is saved with the digital filter effect.

The image is saved with the same recorded pixels and quality.

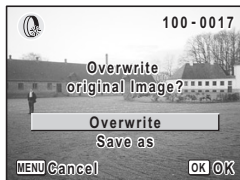

When a digital filter is added, the image is saved as ★★★ (JPEG) even when the quality level is set to TIFF.

# Setting the Printing Service (DPOF)

You can print the DPOF (Digital Print Order Format) set images on the SD Memory Card using a DPOF compatible printer or photo processing lab according to the DPOF settings.

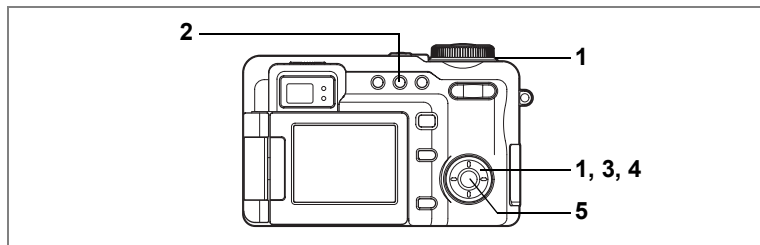

## Printing Single Images

Set the following items for each image.

Copies : Choose the number of copies up to 99.

Date : Specify whether you want the date inserted on the print or not.

**1 Use the front lever or the four-way controller (◀▶) to choose the image to print.**

**2 Press the DPOF button.**

The DPOF screen appears.

**3 Use the four-way controller (◀▶) to choose the number of copies and press the four-way controller (▼).**

The frame moves to [Date].

**4 Use the four-way controller (◀▶) to choose whether to insert the date or not.**

(On) : The date will be imprinted.

(Off) : The date will not be imprinted.



## 5 Press the **OK** button.

The DPOF setting is saved and the screen returns to playback status.



- If DPOF settings have already been made for an image, the previous number of copies and date setting will be displayed.
- To cancel DPOF settings, set the number of copies to [0] and press the **OK** button.



- DPOF settings are not possible for movies or sound-only files.
- Depending on the printer or printing equipment at the photo processing lab, the date may not be imprinted on the pictures even if the DPOF setting was made.

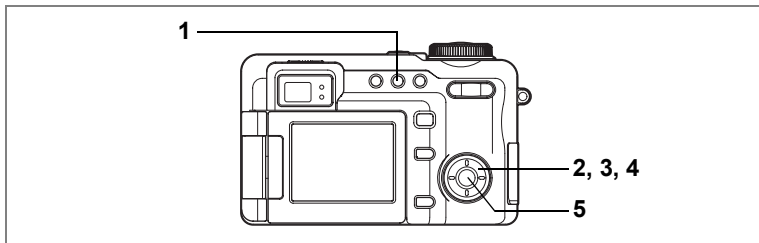

## Printing All Images

### 1 Press the **DPOF** button twice in **Playback** mode.

The DPOF screen for printing all images appears.

### 2 Use the four-way controller (◀▶) to choose the number of copies.

You can print up to 99 copies.

### 3 Press the four-way controller (▼).

The frame moves to [Date].

### 4 Use the four-way controller (◀▶) to choose whether to insert the date or not.

(On) : The date will be imprinted.

(Off) : The date will not be imprinted.

### 5 Press the **OK** button.

The DPOF setting is saved and the screen returns to playback status.

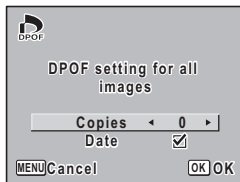

The number of copies specified in the DPOF settings applies to all the images. Before printing, check that the number is correct.



- Settings for single images are canceled when settings are made for all images.
- DPOF settings are not possible for movies or sound only-files.

# Direct Printing Using PictBridge

By connecting the camera to a PictBridge-compatible printer using the USB cable (I-USB7) supplied with the camera, you can print images directly from the camera without using a computer. Connect the camera to the printer and select the images you want to print and the number of copies.

Caution

- You are recommended to use the AC adapter D-AC7 (optional) while the camera is connected to the printer. The printer may not work properly or the image data may be damaged if the battery runs out of power while the camera is connected to the printer.
- Do not disconnect the USB cable during data transfer.
- Depending on the type of printer, not all the settings made on the camera (such as image quality and DPOF settings) may be valid.
- Pictures may not be printed correctly when the camera is connected directly to a PictBridge-compatible printer if the number of copies exceeds 500.
- You cannot choose the print size with the camera. Use the printer to choose the size. For more information, refer to the operating manual for your printer.

6

Editing and Printing Still Pictures

## Connecting the Camera to the Printer

### 1 Select [PictBridge] for [USB Connection] on the [Setup] menu.

Refer to “Changing the USB Connection Mode” (p.161).

### 2 Connect the camera to the printer using the USB cable supplied with the camera.

The PictBridge menu appears.

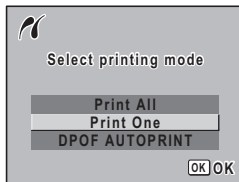

Caution

Do not connect the camera to your computer while [PictBridge] is selected for the USB Connection mode.



## Printing Single Images

- 1 Use the four-way controller (▲▼) to select [Print One] on the PictBridge menu.

- 2 Press the OK button.

The Print One screen appears.

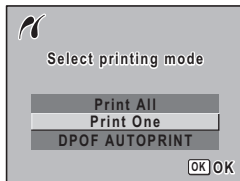

- 3 Use the four-way controller (◀▶) to choose an image to print.

- 4 Use the four-way controller (▲▼) to choose the number of copies.

You can print up to 99 copies.

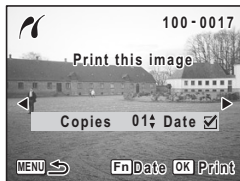

- 5 Use the Fn button to choose whether to insert the date or not.

- (On) : The date will be imprinted.
- (Off) : The date will not be imprinted.

- 6 Press the OK button.

The image is printed according to the settings.

To cancel printing operation, press the **MENU** button.

## Printing All Images

- 1 Use the four-way controller (▲▼) to select [Print All] on the PictBridge menu.



- 2 Press the OK button.

The Print All screen appears.

- 3 Use the four-way controller (▲▼) to choose the number of copies.

The number of copies you choose applies to all the images.

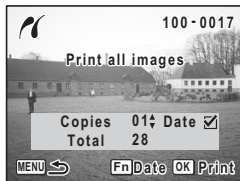

- 4 Use the Fn button to choose whether to insert the date or not.

(On) : The date will be imprinted.

(Off) : The date will not be imprinted.

- 5 Press the OK button.

All the images are printed according to the settings.

To cancel printing operation, press the **MENU** button.

## Printing Images Using the DPOF Settings

**1 Use the four-way controller (▲▼) to select [DPOF AUTOPRINT] on the PictBridge menu.**

**2 Press the OK button.**

The Print w/DPOF settings screen appears. Use the four-way controller (◀▶) to check the images and print settings.

**3 Press the OK button.**

The selected images are printed according to the print settings.

To cancel printing operation, press the **MENU** button.

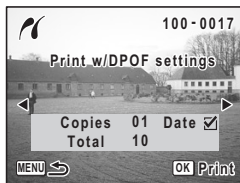

The flash status lamp lights during printing to show that the image data is being transferred to the printer.

## Disconnecting the Camera from the Printer

Disconnect the camera from the printer when you have finished printing.

**1 Disconnect the USB cable from the camera.**

**2 Disconnect the USB cable from the printer.**



The camera automatically turns off when the USB cable is disconnected.

# Recording and Playing Back Sound

## Recording Sound (Voice Recording Mode)

You can record sound with the camera.

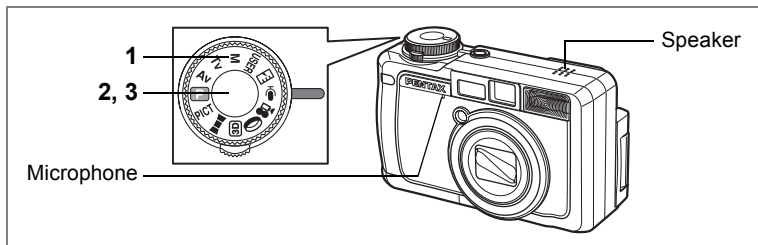

### 1 Set the mode dial to .

The remaining recording time and the recording time of the current file appear on the LCD monitor.

- 1 Recording time
- 2 Remaining recording time

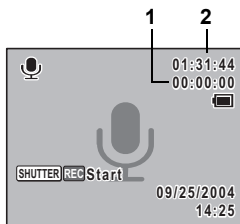

### 2 Press the shutter release button.

Recording starts. The self-timer lamp and flash status lamp light during recording. When the shutter release button is pressed for more than one second, recording continues for as long as the button is held down and stops when the button is released.



### 3 Press the shutter release button.

Recording stops.





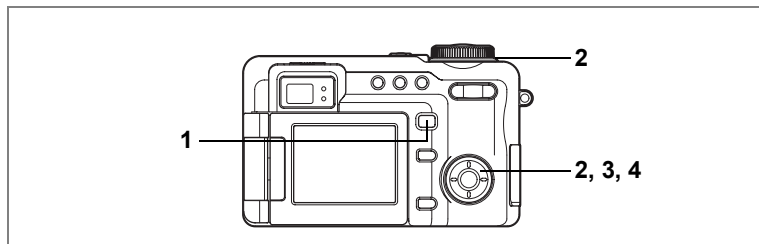

- Sound is saved in WAVE monaural files.
- The microphone is located on the front of the camera. Aim the camera to obtain the best sound.
- Pressing the **OK** button deletes the voice recording screen from the LCD monitor. Press the **OK** button again to display the voice recording screen.

# Playing Back Sound

You can play back the sound files you made in Voice Recording mode.







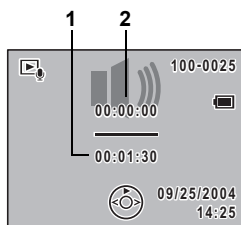

- 1 Press the  button.**
- 2 Use the front lever or the four-way controller ( ) to choose a sound file to play back.**
- 3 Press the four-way controller ()**.

You can play back the sound you have recorded.

- 1 Total file recording time**
- 2 Playback time**



**The following operations can be performed during playback.**

- Four-way controller () Pauses playback  
Press again to resume playback
- Four-way controller () Rewinds and plays back
- Four-way controller () Fast forwards and plays back
- Zoom//Q button () Increases the volume
- Zoom//Q button () Reduces the volume

- 4 Press the four-way controller ()**.

Playback stops.

# Adding a Voice Memo to Images

You can add a 30-second voice memo to your still pictures.

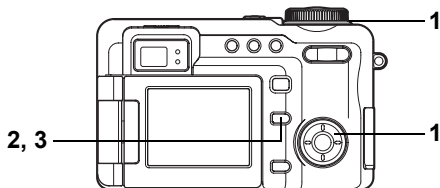

## Recording a Voice Memo

- 1 Enter the Playback mode and use the front lever or the four-way controller (◀▶) to choose the still picture to which you want to add a voice memo.**

🎤 appears on the Fn button operation guide on the LCD monitor if there is no voice memo attached to the displayed image.



- 2 Press the Fn button.**

Recording starts. You can record for up to 30 seconds.

- 3 Press the Fn button.**

Recording stops.

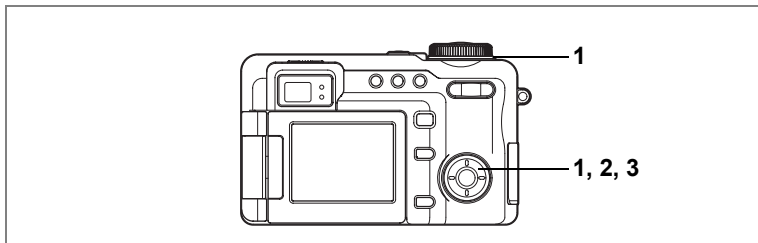

## Playing Back a Voice Memo

- 1 Enter the Playback mode and use the front lever or the four-way controller (◀▶) to choose the still picture with the voice memo to play back.**

If [ ] appears on the displayed image, a voice memo has been recorded.



- 2 Press the four-way controller (▲).**

Playback starts.

**The following operations can be performed during playback.**

Zoom/ [ ] / Q button (▲) Increases the volume

Zoom/ [ ] / Q button (▼) Reduces the volume

- 3 Press the four-way controller (▼).**

Playback stops.

Deleting a Voice Memo ref. p.128



- A voice memo cannot be added to an image which already has a voice memo. Delete the old voice memo and record a new one. (ref. p.128)
- A voice memo cannot be added to protected (🔒) images. (ref. p.131)

# Camera Settings

How to recall the [M] Set-up] menu

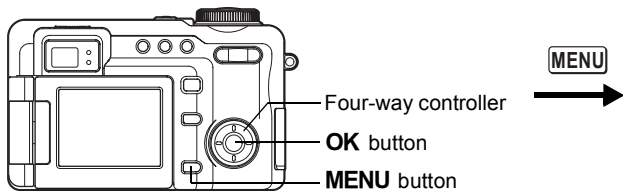

## Formatting an SD Memory Card

Formatting will delete all the data on the SD Memory Card.



- Do not remove the SD Memory Card while the card is being formatted as this may damage the card and render it unusable.
- Formatting will delete protected data too.
- SD Memory Cards formatted on a PC or device other than the camera cannot be used. Be sure to format the card with the camera.

**1 Select [Format] on the [M] Set-up] menu.**

**2 Press the four-way controller (▶).**

The Format screen appears.

**3 Use the four-way controller (▲▼) to select [Format].**

**4 Press the OK button.**

Formatting starts. When formatting is completed, the camera is ready to take pictures.

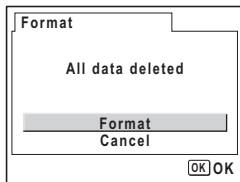



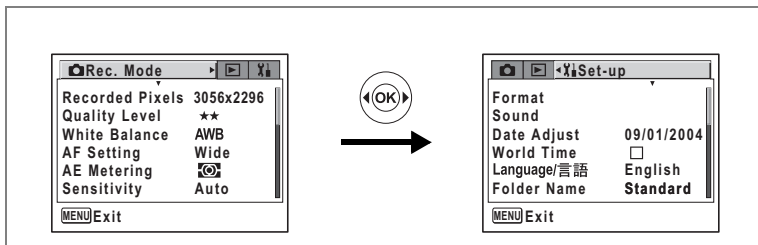

## Changing the Date and Time

You can change the initial date and time settings. You can also set the style in which the date appears on the camera. Choose [mm/dd/yy], [dd/mm/yy] or [yy/mm/dd].

- 1 Select [Date Adjust] on the [Set-up] menu.**
- 2 Press the four-way controller (▶).**

The Date Adjust screen appears.

Refer to "Setting the Date and Time" (p.29) for the setting procedure.

How to recall the [Fn] Set-up] menu

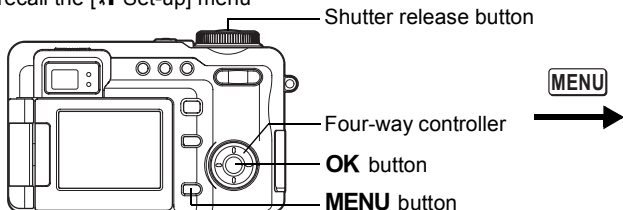

## Changing the Sound Settings

You can adjust the volume of operation sounds and change the type of sound.

- 1 Select [Sound] on the [Fn] Set-up] menu.**
- 2 Press the four-way controller (▶).**

The Sound screen appears.

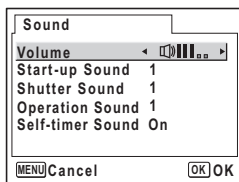

### Changing the Operation Volume

- 3 Use the four-way controller (▲▼) to select [Volume].**
- 4 Use the four-way controller (◀▶) to adjust the volume.**  
Set the volume to "0" to mute operation sounds.

### Changing the Sound Type

- 5 Use the four-way controller (▲▼) to select [Start-up Sound].**
- 6 Press the four-way controller (▶).**  
A pull-down menu appears.
- 7 Use the four-way controller (▲▼) to select [1], [2], [3], [Off] or [USER] and press the four-way controller (◀).**

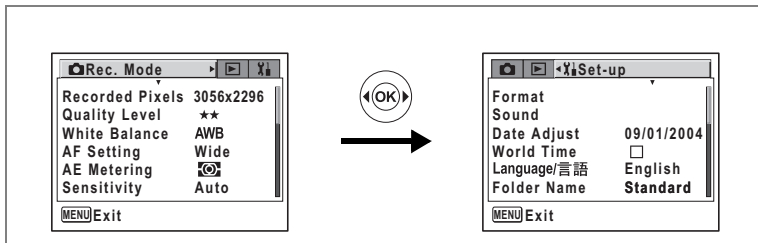

## 8 Repeat Steps 5 to 7 to set the [Shutter Sound], [Operation Sound] and [Self-timer Sound].

Select [On], [Off] or [USER] for the self-timer sound.

## 9 Press the shutter release button.

The setting is saved and the screen returns to capture status. Refer to Step 6 of “How to Use the Menus” (p.43) for other operations after the setting has been made.

### Setting the User Sound

You can set the first two seconds of a previously recorded sound as the user sound and then use this as the start-up sound or shutter sound. The sound to be used in advance is recorded with the camera. (p.146)

## 1 Select [USER] in Steps 7 and 8 above.

## 2 Press the four-way controller (▶).

The Sound screen appears if sounds that can be used as the user sound are recorded in the camera. USER appears for the sound set as the user sound.



## 3 Use the four-way controller (◀▶) to choose a sound file.

Four-way controller (▲) Plays back the first two seconds of the sound file.

Four-way controller (▼) Stops playback.

## 4 Press the OK button.

The selected sound is set as the user sound for the start-up sound or the shutter sound.

How to recall the [Xi Set-up] menu

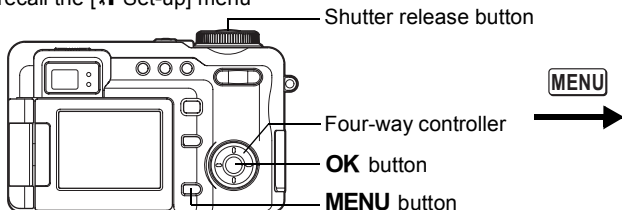

## Setting the World Time

The date and time selected in “Setting the Date and Time” (p.29) serve as the Hometown setting.

You can display the time in a city other than the Hometown. This is useful when taking pictures in a different time zone.

**1 Select [World Time] on the [Xi Set-up] menu.**

**2 Press the four-way controller (▶).**

The World Time screen appears.

**3 Use the four-way controller (◀▶) to select  (On) or  (Off).**

: The time in the city selected in Destination is displayed.

: The time in the city selected in Hometown is displayed.

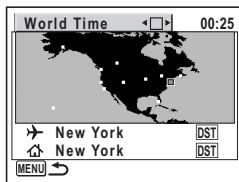

**4 Press the four-way controller (▼).**

The frame moves to ▶ and the ▶ city blinks on the world map.

**5 Press the four-way controller (▶).**

The enlarged Destination screen appears. Press the four-way controller (◀▶) to change the enlarged area.

**6 Press the four-way controller (▼).**

The screen for setting the city appears.

**7 Use the four-way controller (◀▶) to change the Destination city.**

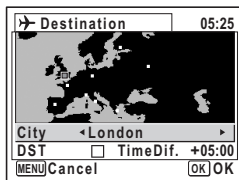

The current time, location and time difference of the selected city appears.

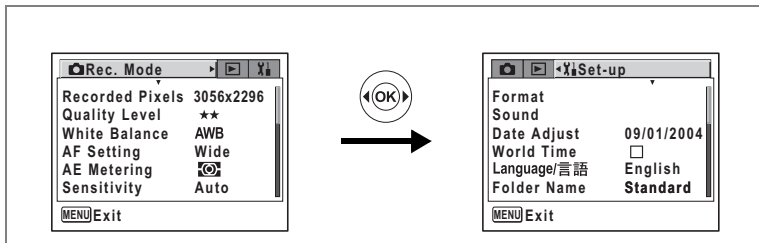

- 8 Use the four-way controller (▼) to select [DST].**
- 9 Use the four-way controller (◀▶) to select  (On) or  (Off).**

Select  (On) if the Destination city is set to daylight saving time.

- 10 Press the shutter release button halfway.**

The World Time setting is saved and the screen returns to capture status.

To continue with World Time setting operations and return to the World Time screen, press the **OK** button.

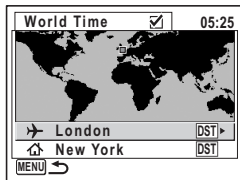

Select  in Step 4 above to set the city and DST setting for the Hometown city.

## Changing the Display Language

You can change the language in which the menus, error messages, etc. are displayed.

You can choose from English, French, German, Spanish, Italian, Russian, Korean, Chinese (traditional and simplified) and Japanese.

- 1 Select [Language/言語] on the [Set-up] menu.**
- 2 Press the four-way controller (▶).**

The Language/言語 screen appears.

Refer to “Setting the Display Language” (p.28) for the setting procedure.

How to recall the [i Set-up] menu

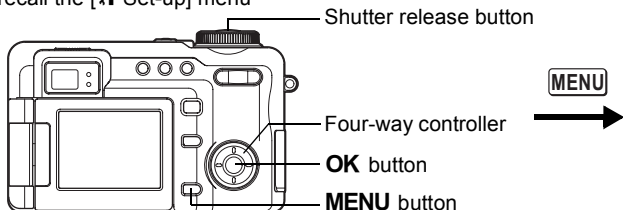

## Changing the Image Folder Name

You can change the setting of the image folder name from the standard name to the date the picture was taken. When the name setting is changed to the date, pictures are saved in separate folders by the date the pictures were taken.

### Image Folder Name

Standard	XXXPENTX (where XXX is the 3-digit folder number)
Date	XXX_mmdd (3-digit folder number_month day)

Picture taken with standard folder name  
(Example: August 25)

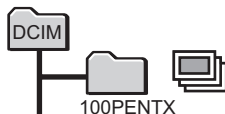

Folder name changed to date setting  
(Example: August 25)

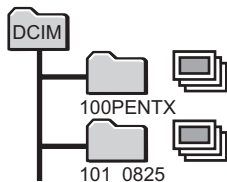

Next time a picture is taken  
(Example: September 3)

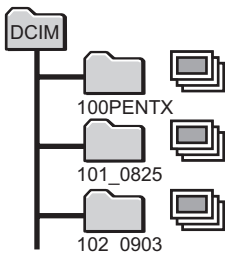

- 1 Select [Folder Name] on the [i Set-up] menu.**
- 2 Press the four-way controller (▶).**  
A pull-down menu appears.
- 3 Use the four-way controller (▲▼) to select [Standard] or [Date].**
- 4 Press the shutter release button halfway.**

The Folder Name setting is saved and the screen returns to capture status. Refer to Step 6 of "How to Use the Menu" (p.43) for other operations after the setting has been made.

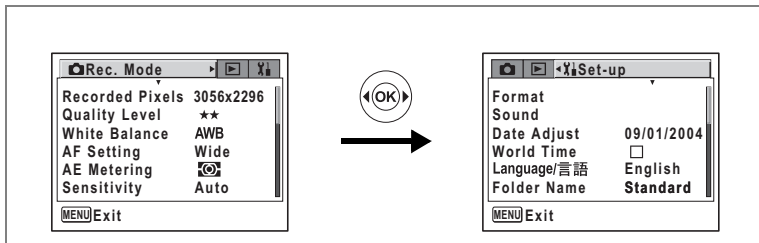

## Changing the Start-up Screen

**1** Select [Start-up Screen] on the [] Set-up menu.

**2** Press the four-way controller ().

The Change Start-up screen appears.

**3** Use the four-way controller ( ) to select  (On) or  (Off).

**4** Press the four-way controller ().

**5** Use the four-way controller ( ) to change the start-up screen.

**6** Press the **OK** button three times.

The Start-up Screen setting is saved and the camera is ready to take or play back images.

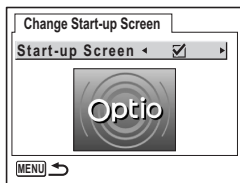

How to recall the [M] Set-up] menu

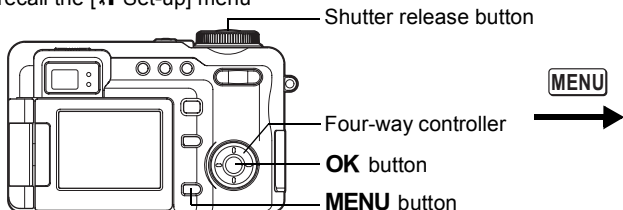

## Customizing the Display Mode

You can customize two user settings to determine the information displayed on the LCD monitor during still image shooting.

When shipped from the factory, Setting 1 is set to full display and Setting 2 is set to display no information.

Refer to p.181 for information that can be displayed.

Displaying Shooting Information in Capture Mode [p.81](#)

- 1 Select [DISPLAY] on the [M] Set-up] menu.**
- 2 Press the four-way controller (▶).**  
The Capture Mode Information Display screen appears.
- 3 Use the four-way controller (▲▼) to select [1] or [2] and press the four-way controller (▶).**

The Setting 1 Setting screen appears when [1] is selected.

The Drive mode icon is surrounded by a frame.

- 4 Use the OK button to hide or display the icon in the frame.**
- 5 Use the four-way controller (▲▼◀▶) to move the frame.**
- 6 Repeat Steps 4 and 5 above to customize the display information.**
- 7 Press the shutter release button halfway.**

The Capture Mode Information Display setting is saved and the screen returns to capture status. Refer to Step 6 of "How to Use the Menus" (p.43) for other operations after the setting has been made.

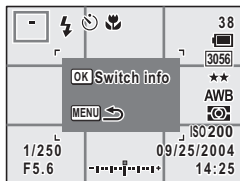
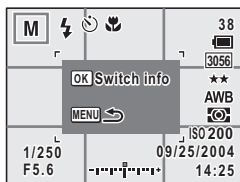



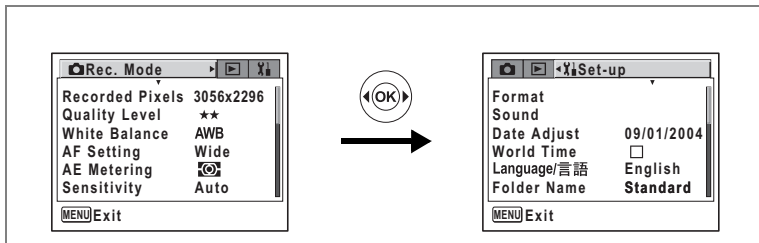

## Adjusting the Brightness of the LCD Monitor

You can adjust the brightness of the LCD monitor.

- 1 Select [Brightness Level] on the [Set-up] menu.**
- 2 Use the four-way controller (◀▶) to adjust the brightness.**

The monitor gets darker as the bar slider moves to the left and brighter as it moves to the right.

- 3 Press the shutter release button halfway.**

The Brightness Level setting is saved and the screen returns to capture status. Refer to Step 6 of “How to Use the Menu” (p.43) for other operations after the setting has been made.

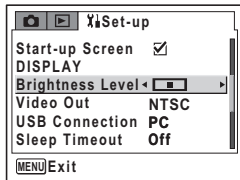

How to recall the [X] Set-up] menu

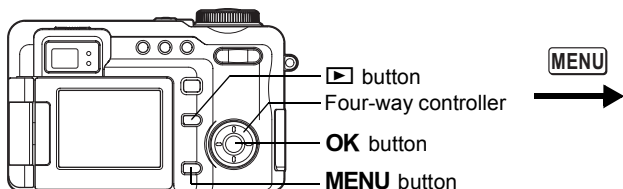

## Changing the Video Output Format

You can choose the output format (NTSC or PAL) for taking or playing back images on a TV.

**1 Select [Video Out] on the [X] Set-up] menu.**

**2 Press the four-way controller (▶).**

A pull-down menu appears.

**3 Use the four-way controller (▲▼) to select [NTSC] or [PAL].**

Choose the video output format to match the output format of the TV.

**4 Press the ▶ button.**

The Video Out setting is saved and the screen returns to playback status. Refer to

Step 6 of “How to Use the Menus” (p.43) for other operations after the setting has been made.

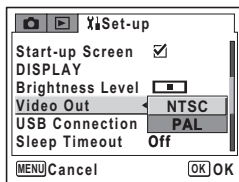

NTSC is the video output format used in North America.

Viewing Still Pictures and Movies on a TV p.126

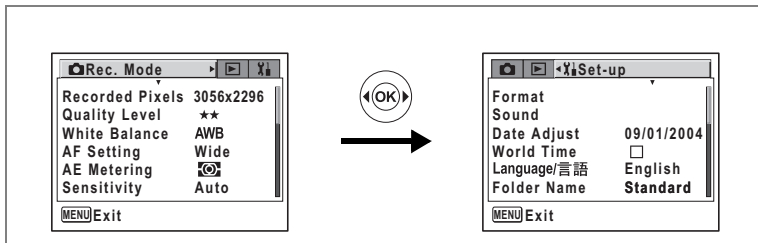

## Changing the USB Connection Mode

Choose the appropriate USB connection mode depending on whether you are going to connect the USB cable to a computer or a PictBridge-compatible printer.

- 1 **Select [USB Connection] on the [Set-up] menu.**
- 2 **Press the four-way controller (▶).**
- 3 **Use the four-way controller (▲ ▼) to select [PC] or [PictBridge].**

[PC] : Select this option when connecting the camera to a computer.

[PictBridge] : Select this option when connecting the camera directly to a PictBridge-compatible printer.

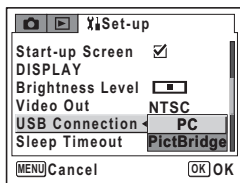

- 4 **Press the [▶] button.**

The USB Connection setting is saved and the screen returns to playback status. Refer to Step 6 of “How to Use the Menu” (p.43) for other operations after the setting has been made.



Do not connect the camera to your computer while [PictBridge] is selected for the USB Connection mode.



Refer to the “PC Guide - Enjoying Your Digital Camera Images On Your PC” for instructions on connecting the camera to a computer.

How to recall the [M] Set-up] menu

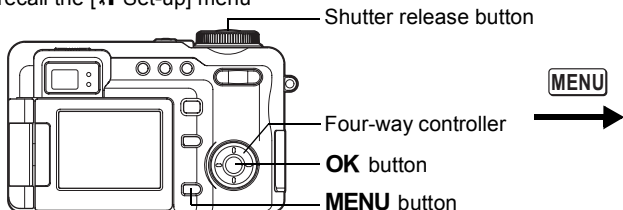

## Setting Sleep Timeout

You can set the LCD monitor to turn off automatically when no operation is performed for a fixed time. Pressing any button other than the power switch during Sleep Timeout will turn the LCD monitor back on.

- 1 Select [Sleep Timeout] on the [M] Set-up] menu.**
- 2 Press the four-way controller (▶).**  
A pull-down menu appears.
- 3 Use the four-way controller (▲▼) to select [2min], [1min], [30sec] or [Off].**
- 4 Press the shutter release button halfway.**

The Sleep Timeout setting is saved and the screen returns to capture status. Refer to Step 6 of "How to Use the Menus" (p.43) for other operations after the setting has been made.



The Sleep Timeout function will not work during a slideshow or movie playback.

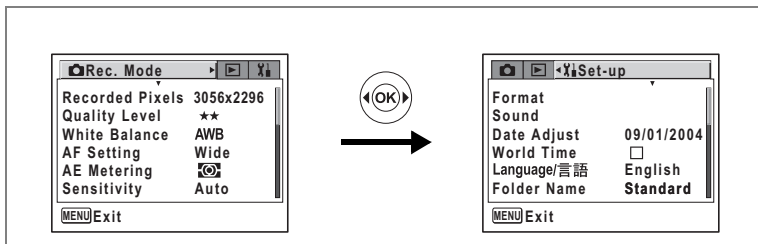

## Setting Auto Power Off

You can set the camera to turn off automatically when no operation is performed for a fixed time.

- 1** Select **[Auto Power Off]** on the **[ Set-up]** menu.
- 2** Press the four-way controller (**▶**).
- 3** Use the four-way controller (**▲ ▼**) to select **[5min]**, **[3min]** or **[Off]**.
- 4** Press the shutter release button.

The Auto Power Off setting is saved and the screen returns to capture status. Refer to Step 6 of “How to Use the Menu” (p.43) for other operations after the setting has been made.



The Auto Power Off function will not work during a slideshow or movie playback.

## Resetting to Default Settings (Reset)

You can reset all the settings other than the Date Adjust, Language/言語 and World Time. Refer to the default setting list (p.179) for the reset settings.

- 1** Select **[Reset]** on the **[ Set-up]** menu.
- 2** Press the four-way controller (**▶**).
- 3** Use the four-way controller (**▲**) to select **[Reset]**.
- 4** Press the **OK** button.

The settings return to the defaults and the camera is ready to take or play back images.

How to recall the [Fn Set-up] menu

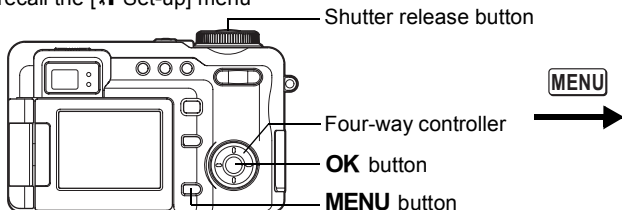

## Registering Functions on the Fn Button

You can use the **Fn** button to quickly make the camera settings. After registering functions to the four-way controller (▲▼◀▶), you can enable these functions simply by pressing the **Fn** button and the four-way controller, rather than having to display the menu with the **MENU** button.

### Registering Functions on the Fn Button

- 1 Select [Fn Setting] on the [Fn Set-up] menu.
- 2 Press the four-way controller (▶).  
The Fn Setting screen appears.
- 3 Use the four-way controller (▲▼) to select the button on the four-way controller to set.
- 4 Press the four-way controller (▶).  
A pull-down menu appears.
- 5 Select the function to register and press the OK button.
- 6 Repeat Steps 3 to 5 to set the other buttons on the four-way controller.
- 7 Press the shutter release button halfway.

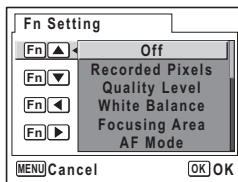
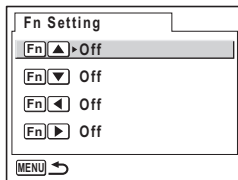

The Fn setting is saved and the screen returns to capture status. Refer to Step 6 of "How to Use the Menus" (p.43) for other operations after the setting has been made.

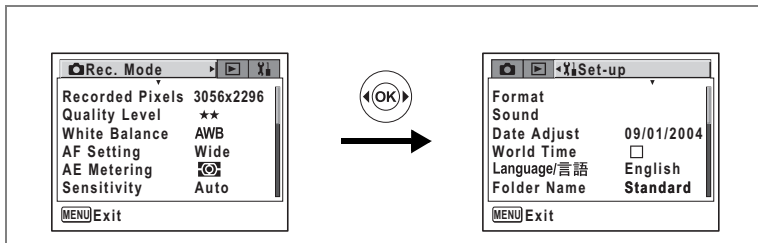

- You can choose from the following 17 functions or Off (no setting): Recorded Pixels, Quality Level, White Balance, Focusing Area, AF Mode, Focus Limiter, Aux. AF Light, AE Metering, Sensitivity, Flash Exp. Comp., Digital Zoom, Image Tone, Sharpness, Saturation, Contrast, Format and MF
- Items with restricted operations in Capture mode have the same restrictions when recalled with the **Fn** button. (For example, the sensitivity cannot be set to Auto during Manual Exposure mode.)

## Using the Fn Switching Function

### 1 Press the Fn button in Capture mode.

The Fn guide screen appears.

The Fn guide screen indicates which functions registered to the buttons, lever or four-way controller can be used.

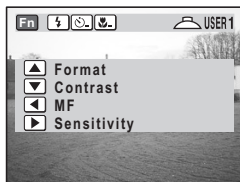

### 2 Press the four-way controller (▶).

The current Sensitivity setting appears in the middle of the screen.

### 3 Use the four-way controller (◀▶) to select the sensitivity.

### 4 Press the OK button.

The Sensitivity setting is saved and the screen returns to capture status.

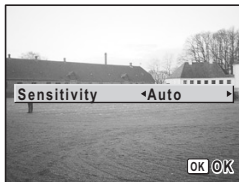

# Setting the Alarm

You can set the alarm to ring at a specified time and display a selected image.

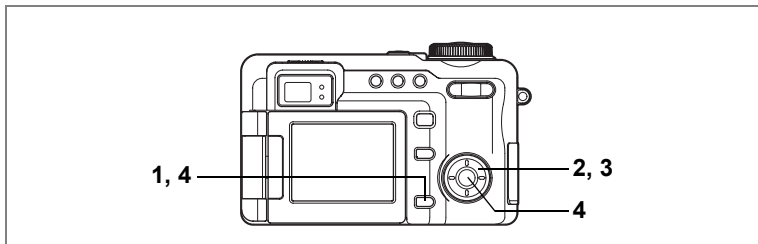

## Checking the Alarm

### 1 Press the **MENU** button in Playback mode.

The [▶ Playback] menu appears.

### 2 Press the four-way controller (▲▼) to select [Alarm].

### 3 Press the four-way controller (▶).

The list of alarms appears.

The checked alarm is turned on. When the snooze function (🔔) is On (☑), the alarm will ring again in a few minutes after it is stopped.

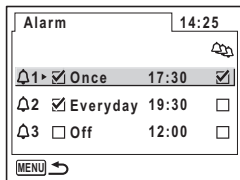

### 4 Press the **MENU** or **OK** button twice.

When the alarm is turned on, "Alarm was set" appears and the camera turns off.



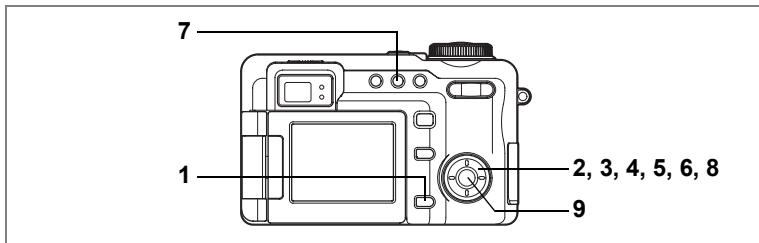

## Setting the Alarm

- 1 Press the MENU button in Playback mode.**

The [▶ Playback] menu appears.

- 2 Press the four-way controller (▲▼) to select [Alarm].**

- 3 Press the four-way controller (▶).**

The list of alarms appears.

- 4 Press the four-way controller (▲▼) to choose Alarm [🔔1], [🔔2] or [🔔3].**

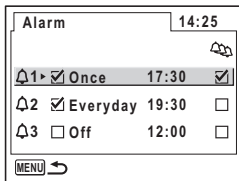

- 5 Press the four-way controller (▶).**

The Alarm screen appears.

- 6 Set the alarm mode, alarm time and snooze function (👉).**

Four-way controller (◀▶) :

selects the item

Four-way controller (▲▼) :

changes the setting

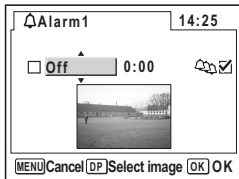

- 7 Press the DPOF button.**

The alarm image options screen appears.

- 8 Use the four-way controller (◀▶) to choose the image to be displayed when the alarm rings.**

- 9 Press the OK button four times.**

When the alarm is turned on, "Alarm was set" appears and the camera turns off.

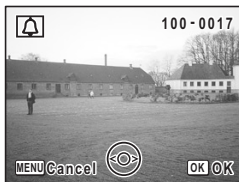

## Stopping the Alarm

The alarm rings for one minute and the selected image is displayed when the set time is reached with the camera turned off.

You can stop the alarm by pressing any button on the camera while the alarm is ringing.

When the snooze function is on, the alarm will ring again in five minutes and continue this five times. You can cancel the snooze function by pressing both the **OK** button and the **MENU** button at the same time.



The alarm will not ring when the set time is reached if the camera is on or during interval shooting standby.

## Digital Exposure Metering Function

The Optio 750Z not only enables you take pictures and record movies as a high quality digital camera; it can also be used as an advanced reflective digital exposure metering. It can also function as a spot exposure metering when the zoom is in the Tele position. When using a single-lens reflex camera or a traditional film camera to take pictures, this digital camera can be used to meter the brightness of various parts of the subject in order to obtain the optimal exposure.

### Digital Exposure Metering Mode

The Digital Exposure Metering mode is used to meter the brightness (light level) of your subject so as to calculate the optimal combination of aperture and shutter speed (exposure). This mode differs from the normal operations used to take pictures and play back images. Metering the light level is as simple as pointing the camera toward the subject and pressing the shutter release button. The Optio 750Z then automatically calculates the shutter speed and aperture according to the brightness of the subject.

### Setting Up the Digital Exposure Metering Mode

To use this camera as a digital exposure metering, first switch to Digital Exposure Metering mode, then set the [Sensitivity], [Exposure Step] and [Color Mode] on the [ Dig. Exp. Metering] menu.



In Digital Exposure Metering mode, only the [ Dig. Exp. Metering] menu can be displayed. The [ Rec. Mode] menu and other menus cannot be displayed.

- 1 Set the mode dial to .**  
The camera switches to Digital Exposure Metering mode.
- 2 Press the MENU button.**  
The [ Dig. Exp. Metering] menu appears.
- 3 Use the four-way controller (▲ ▼) to select [Sensitivity].**

**4 Press the four-way controller (▶).**

The Sensitivity options screen appears.

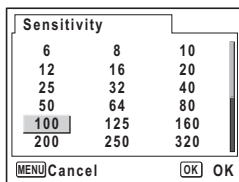
**5 Use the four-way controller (▲▼◀▶) to select the sensitivity of the film loaded in the film camera.**

When you have selected the appropriate sensitivity, press the **OK** button to return to the [M] Dig. Exp. Metering] menu.



The [Sensitivity] setting on the [M] Dig. Exp. Metering] menu is only valid in Digital Exposure Metering mode. The [Sensitivity] setting on the [M] Rec. Mode] menu does not affect the settings in Digital Exposure Metering mode. The [Sensitivity] settings in Digital Exposure Metering mode and Capture mode are not interlinked. The LCD monitor display may not achieve the brightness level corresponding to the selected sensitivity.

**6 Use the four-way controller (▲▼) to select [Exposure Step].****7 Use the four-way controller (▶) to display the Exposure Step options.**

A pull-down menu appears.

**8 Use the four-way controller (▲▼) to choose [1/2EV] or [1/3EV].**

Choose whether to set the exposure in 1/2 EV steps or 1/3 EV steps. When you have selected the exposure step, press the **OK** button to return to the [M] Dig. Exp. Metering] menu.

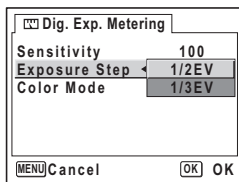

The Exposure Step setting that you have selected affects the EV display on the screen. For example, if you select [1/2EV], the EV scale and exposure metering results described later will be displayed in 1/2 EV steps.

**9 Use the four-way controller (▲▼) to select [Color Mode].**

**10 Press the four-way controller (▶).**

A pull-down menu appears.

**11 Use the four-way controller (▲▼) to choose [Full Color] or [B&W].**

Choose the color mode for display on the LCD monitor in Digital Exposure Metering mode.

When you have selected the color mode, press the **OK** button to return to the [MENU] Dig. Exp. Metering] menu.

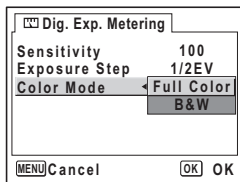

The Color Mode setting does not affect the metering results, but selecting the color mode and type of film lets you envision the resulting picture while taking readings.

**12 Press the MENU button.**

The camera is ready to meter the exposure based on the selected [Sensitivity], [Exposure Step] and [Color Mode].

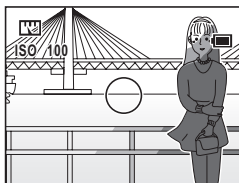
**Metering the Exposure****1 In Digital Exposure Metering mode, point the lens toward the subject.****2 Use the zoom lever to determine the area to meter.**

While viewing the subject on the LCD monitor, adjust the zoom so that the area you want to meter is within the circle (O).

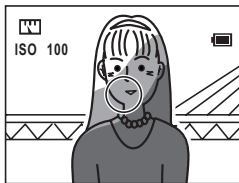

When the zoom is in the Tele position, you can use the camera as a spot exposure metering.

Caution

The digital zoom cannot be used in the Digital Exposure Metering mode. The zoom can only be adjusted within the range of the optical zoom (from  $\times 1$  to  $\times 5$ ).

### 3 Press the shutter release button halfway.

The autofocus locks on the subject and the metering screen appears.

If the subject is too bright or too dark to meter, the EV indicator at the top of the screen blinks.

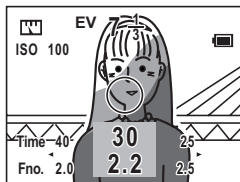

### 4 Press the shutter release button fully.

The exposure value (EV) metered in Step 3 above is stored.

The shutter speed and aperture combination appears. Use the four-way controller ( $\blacktriangleleft \blacktriangleright$ ) to move the combination of values. This combination of values can be displayed in various ways, for example to obtain the aperture that corresponds to the desired shutter speed or to obtain the shutter speed that corresponds to the desired aperture.

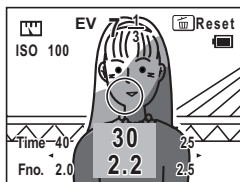

EV is short for “exposure value” and is the value that indicates the exposure brightness (brightness of the subject). EV=0 when the aperture (f-number) is 1.0 and the shutter speed is 1/1.

### 5 Press the OK button.

The screen display during Digital Exposure Metering mode changes to a scale displaying the metered exposure value. This display is called the EV scale.

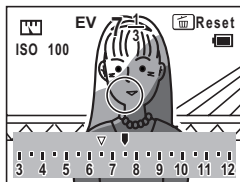

## 6 Repeat Steps 3 and 4 to meter the exposure multiple times.

When you press the **OK** button after metering the exposure, the first (▽) and second (◇) metering results appear on the scale.

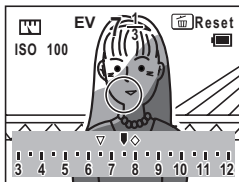

Scale icons

- ▽ : First metered value
- ◇ : Second metered value
- ▼ : Current exposure value (EV)

The first metered value is saved regardless of the number of times you meter the exposure. The third metered value, and all metered values thereafter, overwrite the second metered value and are saved.

Press the  button to delete all metered values, including the first metered value, from the memory. You can start the exposure metering process again.

### Setting the Preferred Exposure

Press the four-way controller (◀▶) while the first and second metered values (or one thereafter) appear on the EV scale to increase or decrease the EV (which represents the standard combination of aperture and shutter speed) in one-half or one-third increments. (Refer to p.169 for instructions on selecting the Exposure Step for increasing and decreasing the EV.) Use this operation to set the EV and then press the **OK** button again. The combination of aperture and shutter speed corresponding to that EV appears (the screen display changes to that in Step 4). Next, use the four-way controller (◀▶) to view the different combinations of apertures and shutter speeds.

With this method, in addition to simply using the metered value as is, you can also obtain a combination of aperture and shutter speed based on a preferred EV using the first and second metered values (or one thereafter).

## Using the Reflected Light Exposure Meter

Reflected light exposure meters, in general, are not used to obtain a single correct exposure. They are normally used to make light readings of various parts of the subject, but the lighting around the subject can greatly affect the camera film (or CCD on a digital camera) due to the color and material of the subject, even under similar lighting conditions. As the metering range can be specified fairly precisely with spot exposure metering such as that provided on this camera, to capture the desired picture with a camera, you must meter the brightness at various points on the subject and then decide which value based on what standard to use in the camera settings. The following describes the common methods for using the exposure value metered with a reflected light exposure meter as a reference for making the appropriate photographic decisions.

### Averaging Reading Method

This method is used to obtain the most suitable exposure value by averaging the brightest area (highlight) of the subject with the darkest area (shadows).

To use the Optio 750Z as an exposure metering with this method, first meter the highlight of the subject and then meter the shadows. As described in Step 6 on p.173, the first and second metered values (and those thereafter) are saved and then appear on the EV scale. The average of those values can be easily derived by using the four-way controller (◀▶) to move the exposure value to the point exactly between the first and second values. This is the average of the two values. Because this method obtains the exposure of the intermediate level between the brightest and darkest areas of the subject, it is effective for capturing a well-rounded picture with balanced lighting. However, when the subject has a significant difference between the highlight and the shadows, it is recommended that you take at least three exposure readings, calculate the average and determine, yourself, which area of the composition represents the intermediate level. To obtain a fairly appropriate exposure value with a single metering, try placing a gray card with a reflectance of 18% perpendicular to the camera's optical axis when taking readings.



## White Point/Black Point Method

The average reading method is generally used to produce a picture with a smooth gradation from the bright areas to the dark areas within the viewing angle.

On the other hand, with the Optio 750Z in the Exposure Metering mode, you can also use a rather specialized reading method that involves making the brightest area within the viewing angle completely white. This lets you take pictures of a subject silhouetted against a pure white background.

To use this method, follow the steps for metering the exposure and displaying the EV scale and then press the button. A white point corresponding to the metered value appears on the EV scale. Use the four-way controller ( ) to set the current exposure value on the EV scale to the white point and then press the **OK** button. The screen display changes to show the combination of aperture and shutter speed appropriate for the current exposure value. By using that combination of values to make the settings on the camera used to take the picture, you can give the bright area a whitish effect.

The opposite approach can also be taken to give the dark area a blackish effect (using the black point). Press the /DPOF button while the EV scale is displayed and a black point appears on the EV scale. Following the same procedure as for the white point method described above, decide the combination of shutter speed and aperture and make the appropriate settings on the camera used to take the picture. When you use the white point or black point method, the resulting picture changes depending on the brightness of the area first metered, so try out different readings.

- : White point
- : Black point

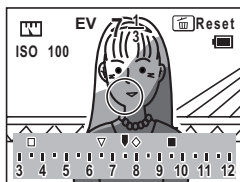

Use the gray scale chart below as a guide when metering the brightness (reflectance) of the subject with a reflected digital exposure metering.



White

Light gray

Medium gray  
(18% reflectance)

Dark gray

Black

## List of World Time Cities

Refer to the following list of cities when setting the World Time.

Region	City	Region	City
North America	Honolulu	Africa/ West Asia	Nairobi
	Anchorage		Jeddah
	Vancouver		Tehran
	San Francisco		Dubai
	Los Angeles		Karachi
	Calgary		Kabul
	Denver		Male
	Chicago		Delhi
	Miami		Colombo
	Toronto		Kathmandu
	New York	Dacca	
	Halifax	East Asia	Yangon
Central and South America	Mexico City		Bangkok
	Lima		Kuala Lumpur
	Santiago		Vientiane
	Caracas		Singapore
	Buenos Aires		Phnom Penh
	Sao Paulo		Ho Chi Minh
	Rio de Janeiro		Jakarta
	Europe		Madrid
London			Beijing
Paris			Shanghai
Milan			Manila
Rome		Taipei	
Berlin		Seoul	
Athens		Tokyo	
Helsinki		Guam	
Moscow		Oceania	Perth
Africa/ West Asia	Dakar		Adelaide
	Algiers		Sydney
	Johannesburg		Noumea
	Istanbul		Wellington
	Cairo		Auckland
	Jerusalem		Pagopago

# Rec. Mode Menus for Each Operation Mode

✓ : Adjustable

– : Operates with initial settings. Any changes made are invalid.

Item	M	Tv	Av	P	PICT	3D	0	Ⓜ	Ⓜ	Ⓜ	Page
Recorded Pixels	✓	✓	✓	✓	✓	✓	✓	–	–	–	p.91
Quality Level	✓	✓	✓	✓	✓	✓	✓	–	–	–	p.93
White Balance	✓	✓	✓	✓	–	✓	✓	✓	–	–	p.95
AF Setting	Focusing Area	✓	✓	✓	✓	✓	✓	✓	–	–	p.97
	AF Mode	✓	✓	✓	✓	✓	✓	✓	–	–	p.97
	Focus Limiter	✓	✓	✓	✓	✓	✓	✓	–	–	p.98
	Aux. AF Light	✓	✓	✓	✓	✓	✓	✓	–	–	p.98
AE Metering	✓	✓	✓	✓	✓	✓	✓	✓	–	–	p.100
Sensitivity	✓	✓	✓	✓	✓	✓	✓	✓	–	–	p.101
Flash Exp. Comp.	✓	✓	✓	✓	✓	✓	✓	–	–	–	p.89
Auto Bracket	✓	✓	✓	✓	✓	–	–	✓	–	–	p.63
Interval Shoot	✓	✓	✓	✓	✓	–	–	✓	–	–	p.66
Movie	Recorded Pixels	–	–	–	–	–	–	–	✓	–	p.111
	Color Mode	–	–	–	–	–	–	–	✓	–	p.112
	Frame Rate	–	–	–	–	–	–	–	✓	–	p.113
	Time-lapse Movie	–	–	–	–	–	–	–	✓	–	p.114
3D Mode	–	–	–	–	–	–	–	–	–	p.78	
Digital Zoom	✓	✓	✓	✓	✓	✓	✓	✓	–	–	p.58
Instant Review	✓	✓	✓	✓	✓	✓	✓	✓	–	–	p.102
Memory	✓	✓	✓	✓	✓	✓	✓	✓	–	–	p.107
Image Tone	✓	✓	✓	✓	–	✓	✓	✓	–	–	p.103
Sharpness	✓	✓	✓	✓	–	✓	✓	✓	–	–	p.104
Saturation	✓	✓	✓	✓	–	✓	✓	✓	–	–	p.105
Contrast	✓	✓	✓	✓	–	✓	✓	✓	–	–	p.106

# Default Settings

The table below lists the factory default settings.  
The following is a description of the table notation.

## Last memory setting

- Yes : The current setting (last memory) is saved even when the camera is turned off.  
No : The setting returns to the default setting when the camera is turned off.  
\* : The setting depends on the Memory setting (p.107).

## Reset setting

- Yes : The setting returns to the default setting with the reset function (p.163).  
No : The setting is saved even after reset.

## ● [📷 Rec. Mode] Menu items

Item		Default Setting	Last Memory Setting	Reset Setting	Page
Recorded Pixels		3056×2296	Yes	Yes	p.91
Quality Level		★★	Yes	Yes	p.93
White Balance		AWB (auto)	*	Yes	p.95
AF Setting	Focusing Area	Wide	Yes	Yes	p.97
	AF Mode	Single	Yes	Yes	p.97
	Focus Limiter	On	Yes	Yes	p.98
	Aux. AF Light	On	Yes	Yes	p.98
AE Metering		 (Multi-segment)	*	Yes	p.100
Sensitivity		Auto	*	Yes	p.101
Flash Exp. Comp.		0	*	Yes	p.89
Auto Bracket		Exposure (±0.3V)	Yes	Yes	p.63
Interval Shoot	Interval	10 sec	Yes	Yes	p.66
	Number of Shot	2 shots	Yes	Yes	p.66
	Start Time	After 0 hr 0 min	Yes	Yes	p.66
Movie	Recorded Pixels	640×480	Yes	Yes	p.111
	Color Mode	Full Color	Yes	Yes	p.112
	Frame Rate	15fps	Yes	Yes	p.113
	Time-lapse Movie	Off	Yes	Yes	p.114
3D Mode		Parallel mode	Yes	Yes	p.78



Digital Zoom		×2	*	Yes	p.58
Instant Review		2 sec	Yes	Yes	p.102
Memory	Flash	On	Yes	Yes	p.87
	Flash Exp. Comp.	Off	Yes	Yes	p.89
	White Balance	Off	Yes	Yes	p.95
	EV Compensation	Off	Yes	Yes	p.59
	Digital Zoom	On	Yes	Yes	p.58
	AE Metering	Off	Yes	Yes	p.100
	Sensitivity	Off	Yes	Yes	p.101
	Focus Mode	Off	Yes	Yes	p.84
	Zoom Position	Off	Yes	Yes	p.57
	MF Position	Off	Yes	Yes	p.85
	DISPLAY	Off	Yes	Yes	p.81 p.121
File #	On	Yes	Yes	—	
Image Tone		Normal	Yes	Yes	p.103
Sharpness		Normal	Yes	Yes	p.104
Saturation		Normal	Yes	Yes	p.105
Contrast		Normal	Yes	Yes	p.106

● [▶ Playback] Menu items

Item		Default Setting	Last Memory Setting	Reset Setting	Page
Slideshow		3sec	Yes	Yes	p.123
Resize		—	No	—	p.133
Trimming		—	No	—	p.135
Digital Filter		B&W	No	—	p.137
Quick Zoom		Off	Yes	Yes	p.120
Quick Delete		Off	Yes	Yes	p.128
Alarm (1, 2, 3)	Alarm selection	Off	Yes	Yes	p.167
	Alarm setting	Off	Yes	Yes	p.167
	Time	00:00	Yes	Yes	p.167
	Snooze function	Off	Yes	Yes	p.167
	Image selection	No image	Yes	Yes	p.167

● [M] Set-up] Menu items

Item		Default Setting	Last Memory Setting	Reset Setting	Page
Format		—	—	—	p.150
Sound	Volume	3	Yes	Yes	p.152
	Start-up Sound	1	Yes	Yes	
	Shutter Sound	1	Yes	Yes	
	Operation Sound	1	Yes	Yes	
	Self-timer Sound	On	Yes	Yes	
Date Adjust	Date Style (date)	According to default setting	Yes	No	p.29
	Date Style (time)	According to default setting	Yes	No	
	Date	According to default setting	Yes	No	
	Time	According to default setting	Yes	No	
World Time	World Time setting	Off	Yes	Yes	p.154
	Destination (city)	Same as Hometown	Yes	No	
	Destination (DST)	Same as Hometown	Yes	No	
	Hometown (city)	According to default setting	Yes	No	
	Hometown (DST)	According to default setting	Yes	No	
Language/言語		According to default setting	Yes	No	p.28
Folder Name		Normal	Yes	Yes	p.156
Start-up Screen	Start-up Screen setting	On	Yes	Yes	p.157
	Image selection	Optio Logo Screen	Yes	Yes	
DISPLAY Setting 1: Full display (Setting 2: No display)	Shooting mode	On (Off)	Yes	Yes	p.158
	Flash mode	On (Off)	Yes	Yes	
	Drive mode	On (Off)	Yes	Yes	
	Focus mode	On (Off)	Yes	Yes	
	Grid display	Off (Off)	Yes	Yes	
	Shutter speed	On (Off)	Yes	Yes	
	Aperture	On (Off)	Yes	Yes	

DISPLAY Setting 1: Full display (Setting 2: No display)	Number of images remaining	On (Off)	Yes	Yes	p.158
	Battery level indicator	On (Off)	Yes	Yes	
	Recorded Pixels	On (Off)	Yes	Yes	
	Quality Level	On (Off)	Yes	Yes	
	White Balance	On (Off)	Yes	Yes	
	AE Metering	On (Off)	Yes	Yes	
	Sensitivity	On (Off)	Yes	Yes	
	Focusing Area	On (Off)	Yes	Yes	
	Exposure bar	On (Off)	Yes	Yes	
	Date and time/ Histogram	Histogram On (Off)	Yes	Yes	
Brightness Level		Normal	Yes	Yes	p.159
Video Out		According to default setting	Yes	No	p.160
USB Connection		PC	Yes	Yes	p.161
Sleep Timeout		1 min	Yes	Yes	p.162
Auto Power Off		3 min	Yes	Yes	p.163
Fn Setting (Up/Down/Left/Right)		Off	Yes	Yes	p.164
USER1, USER2, USER3	Shooting mode	 (Program)	Yes	Yes	p.54
	Recorded Pixels	3056×2296	Yes	Yes	
	Quality Level	★★	Yes	Yes	
	White Balance	Auto	Yes	Yes	
	Focusing Area	Wide	Yes	Yes	
	AF Mode	Single	Yes	Yes	
	AE Metering	 (Multi-segment)	Yes	Yes	
	Sensitivity	Auto	Yes	Yes	
	Flash Exp. Comp.	0	Yes	Yes	
	Digital Zoom	×2	Yes	Yes	
	Image Tone	Normal	Yes	Yes	
	Sharpness	Normal	Yes	Yes	
	Saturation	Normal	Yes	Yes	
	Contrast	Normal	Yes	Yes	
Reset		—	—	—	p.163



## ● Settings in Shooting modes (other than Menu items)

Item		Default Setting	Last Memory Setting	Reset Setting	Page
Program mode	Shutter speed	—	—	—	p.49
	Aperture	—	—	—	
Aperture Priority mode	Shutter speed	—	—	—	p.50
	Aperture	Maximum aperture	Yes	Yes	
Shutter Priority mode	Shutter speed	1/250	Yes	Yes	p.51
	Aperture	—	—	—	
Manual Exposure mode	Shutter speed	1/250	Yes	Yes	p.52
	Aperture	Maximum aperture	Yes	Yes	
User mode		USER1	Yes	Yes	p.53
Picture mode		Landscape	Yes	Yes	p.55
Digital Filter mode		B&W	Yes	Yes	p.74

## ● Key operation

Item		Default Setting	Last Memory Setting	Reset Setting	Page
button	Flash mode	Auto	*	Yes	p.87
button	Drive mode	Single-frame shooting	No	Yes	pp.60 - 73
button	Focus mode	Autofocus mode	*	Yes	p.84
button	Operation mode	Shooting mode	No	—	—
<b>Fn</b> button	Fn guide screen	Off	No	—	p.164
<b>MENU</b> button	Menu screen	Off	No	—	p.42
<b>OK</b> button (when shooting)	Still picture	Normal display	*	Yes	p.81
	Movie	Normal display	*	Yes	
	Sound	Normal display	*	Yes	p.146
<b>OK</b> button (when playing back)	Still picture	Normal display	*	Yes	p.121
	Movie	Normal display	*	Yes	
	Sound	Normal display	*	Yes	p.147
Front lever	EV compensation	0.0EV	*	Yes	p.59
Zoom button	Zoom position	Max. Wide position	*	Yes	p.57

# Optional Accessories

A number of dedicated accessories are available for this camera.

## **AC adapter D-AC7**

## **Rechargeable lithium-ion battery D-LI7 (\*)**

## **Battery charger D-BC7 (\*)**

## **AC plug cord D-CO2 (\*)**

D-CO2A Australia

D-CO2B United Kingdom

D-CO2E Europe

D-CO2H Hong Kong

D-CO2J Japan

D-CO2K Korea

D-CO2U North America, Canada

## **USB cable I-USB7 (\*)**

## **AV cable I-AVC7 (\*)**

## **Strap O-ST17 (\*)**

## **Soft case O-CC7**

## **Remote control unit E**

## **Remote control unit F**

## **3D image viewer O-3DV1**

Products marked with an asterisk (\*) are the same as those supplied with the camera.

# Messages

Messages such as the following may appear on the LCD monitor during camera operation.

Battery depleted	The battery is exhausted. If using a rechargeable battery, charge the battery. (p.14)
No card in camera	This message appears when you press the shutter release button but there is no SD Memory Card in the camera.
Memory card full	The SD Memory Card is full and no more images can be saved. Insert a new SD Memory Card or delete unwanted images. (p.18, p.127) Change the quality level or recorded pixels of recorded images and try again. (p.133)
Memory card error	Shooting and playback are impossible due to a problem with the SD Memory Card. You may be able to use it with your computer to display or copy any images on the card.
Card not formatted	The SD Memory Card you have inserted is unformatted or has been formatted on a computer or other device and is not compatible with this camera. (p.150)
Formatting	The SD Memory Card is being formatted.
Card locked	The SD Memory Card is write-protected. (p.19)
Compression error	This message appears when you have exceeded the capacity limit of the SD Memory Card while taking pictures.
No image and sound	There are no image/sound files on the SD Memory Card.
Movie recording stopped	This message appears when the internal temperature of the camera has exceeded normal operating limits while recording a movie.
Operation terminated due to high temperatures	This message appears when the internal temperature of the camera has exceeded normal operating limits. The camera turns off after displaying the message.
Start interval shooting	This message appears when interval shooting starts and the camera enters standby.







Stop interval shooting?	This message appears when you turn on the camera during interval shooting standby.
Interval Shooting is completed	This message appears when interval shooting is canceled or before the camera automatically turns off after taking the set number of pictures.
Deleting	This message appears when deleting an image.
Camera cannot display this image	You are trying to play back an image in a format not supported by this camera. You may be able to play it back on another brand of camera or your computer.
Image folder could not be created	The largest file number has been assigned to an image in the largest folder number and no more images can be saved. Insert a new SD Memory Card or format the SD Memory Card. (p.150)
Image protected	The image or sound file you are trying to delete is protected.
Data being recorded	This message appears when you try to switch to Movie mode or Playback mode while an image is still being recorded, or when the protect setting or DPOF setting is being changed. It disappears after the image is recorded or the setting is changed.
Data being processed	This message appears when the camera takes more than five seconds to display an image due to, for example, image processing.
Alarm was set	This message appears when the alarm is set and before the camera automatically turns off.









Messages such as the following may appear on the LCD monitor when using the PictBridge function.

No paper in a printer	There is no paper in the printer.
No ink in a printer	There is no ink in the printer.
Printer error	An error message has been sent from the printer.
Data error	A data error message has been sent from the printer.
Paper stuck in a printer	The paper is stuck in the printer.

# Troubleshooting

Problem	Cause	Remedy
Camera will not turn on	Battery is not installed	Check if battery is installed. If not, install battery.
	Battery is installed incorrectly	Check orientation of battery. Reinsert battery according to the ⊕ ⊖ symbols on the battery compartment. (p.15)
	Battery power is low	Charge the battery or use the AC adapter.
No image on the LCD monitor	Camera is connected to a computer by the USB cable	LCD monitor is off when camera is connected to a computer.
	Camera is connected to a TV	LCD monitor is off when camera is connected to a TV.
	LCD monitor is set to OFF	Press the <b>OK</b> button to turn LCD monitor on. (p.81)
	Image is displayed but is hard to see	Image on LCD monitor may be hard to see when taking pictures outside in sunlight. Increase brightness of LCD monitor. (p.159)
Shutter will not release	Flash is charging	Pictures cannot be taken while the flash is charging. Wait until charging is finished.
	No available space on SD Memory Card	Insert SD Memory Card with available space or delete unwanted images. (p.18, p.127)
	Recording	Wait until recording is finished.

Problem	Cause	Remedy
Picture is dark	Subject is too far away in a dark environment, such as a night scene	Picture becomes dark if subject is too far away. Take picture within range of flash.
	Background is dark	When taking a picture of a person against a dark background, such as a night scene, the person may appear dark if the flash does not reach the background even with the correct exposure. Set to  in Picture mode to ensure both person and background are clear. (p.55)
Subject is not in focus	Subject is difficult to focus on	Subjects difficult to focus on using autofocus: objects with little contrast (blue sky, white walls, etc.), dark objects, finely patterned objects, fast-moving objects, scenery through window or net, etc. Lock focus on another object located at same distance (press shutter release button halfway), then aim at target and press shutter release button fully, or use Manual Focus mode. If subject is too dark, use auxiliary AF light for easier focusing. (p.98)
	Subject is not in focusing area	Position subject in focusing area in middle of LCD monitor. If the subject is outside the focusing area, aim the camera at the subject and lock the focus (press shutter release button halfway), then compose picture and press the shutter release button fully.
	Subject is too close	Set focus mode on  or  . (p.84)
	Focus mode is set to  or 	Normal pictures will be out of focus if taken with focus mode set on  or  .

Problem	Cause	Remedy
Flash does not discharge	Flash mode is set to  (flash off)	Set to Auto or  . (p.87)
	 mode Drive mode is set to  or  Focus mode is set to  or  Picture mode is set to 	Flash will not discharge in these modes.
Zoom will not work	Focus mode is set to 	Zoom does not function in Super Macro mode.
USB connection with computer does not work properly	USB Connection mode is set to [PictBridge]	Set USB Connection mode on camera to [PC]. (p.161)

# Main Specifications

Type	Fully automatic compact digital still camera with built-in zoom lens		
Effective Pixels	7 megapixels		
Sensor	7.41 megapixels (total pixels) 1/1.8 inch interline transfer CCD with a primary color filter		
Recorded Pixels	Still Picture	Aspect ratio 4:3	3056×2296 pixels, 2592×1944 pixels, 2048×1536 pixels, 1600×1200 pixels, 1024×768 pixels, 640×480 pixels
		Aspect ratio 3:2	3056×2040 pixels, 2592×1728 pixels, 2048×1368 pixels, 1600×1064 pixels, 1024×680 pixels, 640×424 pixels
	Movie	Aspect ratio 4:3	640×480 pixels, 320×240 pixels
Sensitivity	Auto, manual (80/100/200/400: Standard Output Sensitivity)		
File Format	Still Picture	TIFF, JPEG (Exif 2.2), DCF, DPOF, PictBridge, PRINT Image Matching	
		MOV (QuickTime MotionJPEG), streaming video, approx. 30fps, approx. 15fps (PCM system, monaural)	
	Sound	Voice memo, voice recording: PCM system, monaural	
Quality Level	Still Picture	TIFF, ★★★ "Best", ★★ "Better", ★ "Good"	
	Picture		
Storage Medium	SD Memory Card		

## Image Storage Capacity and Recording Time (when using a 64MB SD Memory Card)

### Still Picture (approximate number of images)

Recorded Pixels		Quality Level			
Aspect Ratio	Number of Pixels	TIFF	★★★ Best	★★ Better	★ Good
4:3	3056×2296	2 pictures	15 pictures	30 pictures	47 pictures
	2592×1944	4 pictures	22 pictures	44 pictures	67 pictures
	2048×1536	—	34 pictures	67 pictures	101 pictures
	1600×1200	—	56 pictures	110 pictures	149 pictures
	1024×768	—	121 pictures	215 pictures	298 pictures
	640×480	—	258 pictures	352 pictures	484 pictures
3:2	3056×2040	—	17 pictures	34 pictures	56 pictures
	2592×1728	—	24 pictures	47 pictures	75 pictures
	2048×1368	—	38 pictures	75 pictures	121 pictures
	1600×1064	—	61 pictures	121 pictures	184 pictures
	1024×680	—	149 pictures	242 pictures	322 pictures
	640×424	—	298 pictures	387 pictures	484 pictures



Movie (approximate recording time)

Recorded Pixels	Frame Rate	30fps	15fps	Sound
	640×480		50 sec.	1 min. 50 sec.
320×240		1 min. 30 sec.	2 min. 50 sec.	

White Balance	Auto, Daylight, Shade, Tungsten Light, Fluorescent Light (W/N/D), Manual			
Lens	Focal Length	7.8mm - 39 mm (equivalent to 37.5 mm - 187.5 mm in 35 mm format)		
	Maximum Aperture	f2.8 - f4.6		
	Lens Composition	9 elements in 7 groups (two aspherical elements)		
	Zoom Type	Electrically driven		
	Picture Range	Approx. 33.7 mm × approx. 24.7 mm (screen is filled) (Super Macro mode)		
Digital Zoom	Capture Mode	Max. 8× (combines with 5× optical zoom to give zoom magnification equivalent to 40×)		
Viewfinder	Type	Real-image zoom viewfinder (diopter adjustable from -3 m <sup>-1</sup> to +1 m <sup>-1</sup> )		
	Magnification	Wide: 0.37×, Tele: 1.66×		
LCD Monitor	1.8 inch CG silicon TFT color LCD monitor (microreflective), with brightness adjustment, approx. 134 kilopixels (with backlight), with swivel mechanism (270° vertically and 180° horizontally)			
Playback Function	Single-frame, 9-frame index, enlargement (max. 10×), scroll, rotating, sound, slideshow, movie playback, histogram display, digital filter, trimming, resize			
Focus Mode	Auto Focus, Macro, Super Macro, Manual Focus, Focusing Area			
Autofocus	Type	TTL contrast detection system by sensor (with external passive sensor) 11 point autofocus (wide/spot changeable)		
	Distance measuring mode	Single, continuous		
	Focusing Range (from lens front)	Normal	: Approx. 0.6 m - ∞ (full zoom range)	
		Macro	: Approx. 0.15 m - 0.65 m (full zoom range)	
		Super Macro	: Approx. 0.02 m - 0.65 m (Wide only)	
	Landscape	: ∞ (full zoom range)		
Focus Lock	By half-pressing shutter release button			
Auxiliary AF light	LED automatically lights in dim surrounding light			

Manual Focus	Focusing Range	0.02 m - ∞ (Wide), 0.15 m - ∞ (full zoom range)
Exposure Mechanism	AE Metering	TTL metering by sensor (multi-segment, center-weighted, spot)
	EV Compensation	±2 EV (can be set in 1/3 EV steps)
	Capture mode	Program ( <b>P</b> ), Aperture Priority ( <b>Av</b> ), Shutter Priority ( <b>Tv</b> ), Manual ( <b>M</b> ), Picture, Movie, 3D Image, Panorama Assist, Digital Filter, User
	Dig. Exp. Metering mode	Can be used as a reflected light digital exposure metering.
Picture Modes	Landscape, Portrait, Self-portrait, Night Scene, Night Scene Portrait, Sport, Flower, Fireworks, Surf&Snow, Autumn Colors, Sunset, Food	
Digital Filters	B&W, Sepia, Red, Pink, Purple, Blue, Green, Yellow, SOFT (can be added before or after taking pictures) Brightness (can only be added after taking pictures)	
Auto Bracket	Exposure, White Balance, Saturation, Sharpness, Contrast	
Movie	Continuous recording time	1 sec. - SD Memory Card becomes full.
Shutter	Type	Electronic/mechanical shutter
	Speed	Approx. 1/2000 sec. - 15 sec. (Manual Exposure, Shutter Priority: Approx. 1/1000 sec., noise reduction function available when more than 1 sec.)
Flash	Type	Built-in flash with red-eye reduction function
	Flash Modes	Auto (at low illumination), Flash Off, Flash On, Auto + Red-eye Reduction, Flash On + Red-eye Reduction, Slow Synchronization (Night Scene, Night Scene Portrait, Sunset only)
	Working Range	Wide : approx. 0.4 m - 5.2 m (Sensitivity: Auto)
		Tele : approx. 0.15 m - 3.2 m (Sensitivity: Auto)
Flash Exposure Compensation	±1/2 EV (can be set in 1/3 EV steps)	
Drive Modes	Single-frame, 10-sec. Self-timer, 2-sec. Self-timer, Instant Remote Control, 3-sec. Remote Control, Continuous, Interval Shooting, Multiple Exposure, Auto Bracket (Exposure, White Balance, Saturation, Sharpness, Contrast) Simultaneous settings (Multiple Exposure+Self-timer/Remote Control, Auto Bracket+Self-timer/Remote Control)	
Self-Timer	Electronic control type, control time: approx. 10 sec., 2 sec.	

Remote Control	PENTAX remote control units E and F (optional) Camera can be set to start exposure either instantly after receiving the signal or three seconds after receiving the signal from the remote control. Zoom can be operated with remote control unit E.	
Time Function	World Time setting for 68 cities (28 time zones)	
Alarm	Alarm with simultaneous display of selected image at specified time (max. 3 alarms) and snooze function	
Power Supply	Lithium-ion battery D-LI7, AC adapter (optional)	
Battery Life (Image storage capacity)	Approx. 245 pictures	(at 23°C with flash fired for 50% of shots and with lithium-ion battery D-LI7 in accordance with CIPA measuring conditions)
In/Out Port	USB/AV terminal (PC communication type USB 1.1), external power supply terminal	
Video Output Format	NTSC/PAL (monaural)	
PictBridge	Printer	PictBridge-compatible printer
	Print Modes	Print One, Print All, DPOF AUTOPRINT
Size	100 (W)×61.5 (H)×42 (D) mm (excluding operating members)	
Weight	210 g (excluding battery and SD Memory Card)	
Weight when shooting	255 g (including battery D-LI7 and SD Memory Card)	
Package Contents	Rechargeable lithium-ion battery, battery charger, USB cable, AV cable, software (CD-ROM), strap, SD Memory Card, AC plug cord, operating manual	

# WARRANTY POLICY

All PENTAX cameras purchased through authorized bona fide photographic distribution channels are guaranteed against defects of material or workmanship for a period of twelve months from date of purchase. Service will be rendered, and defective parts will be replaced without cost to you within that period, provided the equipment does not show evidence of impact, sand or liquid damage, mishandling, tampering, battery or chemical corrosion, operation contrary to operating instructions, or modification by an unauthorized repair shop. The manufacturer or its authorized representatives shall not be liable for any repair or alterations except those made with its written consent and shall not be liable for damages from delay or loss of use or from other indirect or consequential damages of any kind, whether caused by defective material or workmanship or otherwise; and it is expressly agreed that the liability of the manufacturer or its representatives under all guarantees or warranties, whether expressed or implied, is strictly limited to the replacement of parts as hereinbefore provided. No refunds will be made on repairs by non-authorized PENTAX service facilities.

## Procedure During 12-month Warranty Period

Any PENTAX which proves defective during the 12-month warranty period should be returned to the dealer from whom you purchased the equipment or to the manufacturer. If there is no representative of the manufacturer in your country, send the equipment to the manufacturer, with postage prepaid. In this case, it will take a considerable length of time before the equipment can be returned to you owing to the complicated customs procedures required. If the equipment is covered by warranty, repairs will be made and parts replaced free of charge, and the equipment will be returned to you upon completion of servicing. If the equipment is not covered by warranty, regular charges of the manufacturer or of its representatives will apply. Shipping charges are to be borne by the owner. If your PENTAX was purchased outside of the country where you wish to have it serviced during the warranty period, regular handling and servicing fees may be charged by the manufacturer's representatives in that country. Notwithstanding this, your PENTAX returned to the manufacturer will be serviced free of charge according to this procedure and warranty policy. In any case, however, shipping charges and customs clearance fees to be borne by the sender. To prove the date of your purchase when required, please keep the receipt or bills covering the purchase of your equipment for at least a year. Before sending your equipment for servicing, please make sure that you are sending it to the manufacturer's authorized representatives or their approved repair shops, unless you are sending it directly to the manufacturer. Always obtain a quotation for the service charge, and only after you accept the quoted service charge, instruct the service station to proceed with the servicing.

- This warranty policy does not affect the customer's statutory rights.
- The local warranty policies available from PENTAX distributors in some countries can supersede this warranty policy. Therefore, we recommend that you review the warranty card supplied with your product at the time of purchase, or contact the PENTAX distributor in your country for more information and to receive a copy of the warranty policy.



The CE Mark is a Directive conformity mark of the European Community.

## **For customers in USA**

### **STATEMENT OF FCC COMPLIANCE**

This device complies with Part 15 of the FCC Rules. Operation is subject to the following two conditions: (1) This device may not cause harmful interference, and (2) this device must accept any interference received, including interference that may cause undesired operation.

Changes or modifications not approved by the party responsible for compliance could void the user's authority to operate the equipment.

This equipment has been tested and found to comply with the limits for a Class B digital device, pursuant to part 15 of the FCC Rules.

These limits are designed to provide reasonable protection against harmful interference in a residential installation. This equipment generates, uses and can radiate frequency energy and, if not installed and used in accordance with the instructions, may cause harmful interference to radio communications. However, there is no guarantee that interference will not occur in a particular installation.

If this equipment does cause harmful interference to radio or television reception, which can be determined by turning the equipment off and on, the user is encouraged to try to correct the interference by one or more of the following measures:

- Reorient or relocate the receiving antenna.
  - Increase the separation between the equipment and receiver.
  - Connect the equipment into an outlet on a circuit different from that to which the receiver is connected.
- \* Consult the dealer or an experienced radio/TV technician for help.

## **For customers in Canada**

This Class B digital apparatus meets all requirements of the Canadian Interference - Causing Equipment Regulations.

## **Pour les utilisateurs au Canada**

Cet appareil numérique de la classe B respecte toutes les exigences du Règlement sur le matériel brouilleur du Canada.

**Declaration of Conformity**  
According to 47CFR, Parts 2 and 15 for  
**Class B Personal Computers and Peripherals**

We: PENTAX Imaging Company  
A Division of PENTAX of America, Inc.

Located at: 600 12<sup>th</sup> Street, Suite 300  
Golden, Colorado 80401 U.S.A.  
Phone: 303-799-8000 FAX: 303-790-1131

Declare under sole responsibility that the product identified herein complies with 47CFR Parts 2 and 15 of the FCC rules as a Class B digital device. Each product marketed is identical to the representative unit tested and found to be compliant with the standards. Records maintained continue to reflect the equipment being produced can be expected to be within the variation accepted, due to quantity production and testing on the statistical basis as required by 47CFR §2.909. Operation is subject to the following two conditions: (1) This device may not cause harmful interference, and (2) This device must accept any interference received, including interference that may cause undesired operation. The above named party is responsible for ensuring that the equipment complies with the standards of 47CFR §15.101 to §15.109.

Product Name: PENTAX Digital Still Camera

Model Number: Optio 750Z

Contact person: Customer Service Manager

Date and Place: August, 2004, Colorado

- PENTAX Corporation** 2-36-9, Maeno-cho, Itabashi-ku, Tokyo 174-8639, JAPAN  
(<http://www.pentax.co.jp/>)
- PENTAX Europe GmbH (European Headquarters)**  
Julius-Vosseler-Strasse, 104, 22527 Hamburg, GERMANY  
(HQ - <http://www.pentaxeurope.com>)  
(Germany - <http://www.pentax.de>)
- PENTAX U.K. Limited** PENTAX House, Heron Drive, Langley, Slough, Berks  
SL3 8PN, U.K.  
(<http://www.pentax.co.uk>)
- PENTAX France S.A.S.** 12/14, rue Jean Poulmarch, 95106 Argenteuil Cedex, FRANCE
- PENTAX Benelux B.V.** (for Netherlands)  
Spinveld 25, 4815 HR Breda, NETHERLANDS  
(<http://www.pentax.nl>)  
(for Belgium & Luxembourg)  
Weiveldlaan 3-5, 1930 Zaventem, BELGIUM  
(<http://www.pentax.be>)
- PENTAX (Schweiz) AG** Widenholzstrasse 1 Postfach 367 8305 Dietlikon, SWITZERLAND  
(<http://www.pentax.ch>)
- PENTAX Scandinavia AB** P.O. Box 650, 75127 Uppsala, SWEDEN  
(<http://www.pentax.se>)
- PENTAX Imaging Company**  
A Division of PENTAX of America, Inc.  
600 12<sup>th</sup> Street, Suite 300  
Golden, Colorado 80401, U.S.A.  
(<http://www.pentax.com>)
- PENTAX Canada Inc.** 1770 Argentia Road Mississauga, Ontario L5N 3S7,  
CANADA  
(<http://www.pentaxcanada.ca>)

<http://www.digital.pentax.co.jp>



for your  
precious moments

- Printed on recycled paper
- Specifications and external dimensions are subject to change without notice.